

information Bulletin



WESTERN ASSOCIATION OF MAP LIBRARIES

“. . . to encourage high standards in every phase of organization
and administration of map libraries . . .”

Information Bulletin

VOL. 6, NO. 1

NOV. 1974

Western Association of Map Libraries

Contents

Cadastral Maps: Tools for Agricultural Development [in Taiwan] by Prof. Paul Vander Meer	3
New WAML Members and Subscribers	10
New Development in Promotion of WAML & <u>Information Bulletin</u>	12
A Primer on Map Folds and Map Folding, by Harold Otness	13
Atlases Cataloged at UCLA, by Anna F. Blustein	17
Abbreviations and Acronyms in the Mapping Sciences: a first listing by Prof. Harry J. Steward	27
Map Catalogers Beware! L.C. to revise Class G Schedule	32
Geography & Map Division, SLA, Annual Meeting, Toronto, by Mary Larsgaard	33
WAML Program, General Membership Meeting, San Francisco, Oct. 24-25, 1974	35
<u>WAML's Spring Meeting Announced for Vancouver, B.C., May 8-10, 1975</u>	36
WAML General Membership Meetings, a Chronology 1966-1974	36
U.S. Federal Map & Chart Depositories, by Robert Sivers	37
Western Michigan University's MA Degree for Map Librarians	44
The Midwest "Goes to Press"; Genesis of a Newsletter, by Patricia Moore	45
New Mapping of Western North America, contributions by Mary Blakeley, Phil Hoehn, Susan Trevitt, and The Editor	50
Map Librarianship Job Openings	55
Publications of Relevance, contributions by A. J. Thompson, Larry Cruse, Edward Thatcher, Evelyn Woodruff, Patricia Alonso, and The Editor	56
Gifts & Exchange	64
Bench Marks! [Personal news of WAML Members]	65
WAML Income-Expense Report, Fiscal Year 1973/74 ending June 30, 1974	66

Officers of the Western Association of Map Libraries 1974/75

President: Gail N. Neddermeyer, Documents Dept; Univ. of Calif. Berkeley

Pres.-Elect: Mary Larsgaard, Documents Dept; Central Washington State
College, Ellensburg

Secretary: R. Philip Hoehn, Bancroft Library; Univ. of Calif. Berkeley

Treasurer: Stanley D. Stevens, Map Collection; Univ. Calif. Santa Cruz

Past Pres.: Beatrice L. Lukens, Earth Sci. Lib; Univ. Calif. Berkeley



US ISSN 0049 - 7282

LC# 72 - 625238

The Information Bulletin is published by the Western Association of Map Libraries, but opinions expressed herein do not necessarily reflect an official position of the Association.

Membership in WAML is open to any individual, institution, or business interested in furthering the Purpose of the Association (to encourage high standards in every phase of the organization and administration of map libraries).

Membership Dues:

Principal Region

Alberta
British Columbia

Alaska
Arizona
California
Colorado
Hawaii
Idaho
Montana
Nevada
New Mexico
Oregon
Utah
Washington
Wyoming

Individual Members residing within the Principal Region may participate by serving as an Officer, vote, attend meetings, and receive the Information Bulletin. \$5.00 per fiscal year (July thru June); mid-year joiners will receive back-issues of the Information Bulletin for that year.

Associate Members are those who reside outside the Principal Region, and may participate by attending meetings, serving in an advisory capacity on a committee, and receive the Information Bulletin. \$5.00 per fiscal year.

Lifetime Individual Membership is open to individuals only for a onetime payment of \$200. All Lifetime Members may participate with the same rights as Individual Members, but in addition to the Information Bulletin will receive a copy of each Occasional Paper.

Institutional Members are commercial firms or educational organizations. The Institution may designate one of its staff to be the official representative for attendance at meetings. The official representative has all the rights of Individual Membership, but may not hold office. The Institution will receive one copy of each issue of the Information Bulletin and each Occasional Paper issued during the year of membership). \$25.00 per fiscal year.

Back issues of the Information Bulletin are available for \$5.00 per volume, or portion thereof, from the Editor.

Subscriptions to the Information Bulletin are available at \$5.00 per volume-year; three issues per volume-year: November, March, June.

Editor: Stanley D. Stevens
University Library
University of California
Santa Cruz, CA 95064 (phone ac408/429-2364)

The Information Bulletin is indexed in *Library Literature*, and *Library and Information Science Abstracts*; *Surveying and Mapping/American Cartographer*; and, IREBI [*Indices de Revistas de Bibliotecologia*] (Argentina).

COPY DEADLINES: # 1 - October 1st; # 2 - February 1st; # 3 - May 1st.

CADASTRAL MAPS: TOOLS FOR AGRICULTURAL DEVELOPMENT

by Paul Vander Meer

The purpose of this paper is to show how using the cadastral map of Chulin Village, Taiwan, led to uncovering the role which joint landownership has played in curtailing and even reversing the agriculturally deleterious process of farm fragmentation.

In Europe, where individual plot ownership obtains, the process of farm fragmentation is viewed as "inevitable" where primogeniture is absent, transportation and irrigation systems are being expanded in rural areas, and especially where rural population growth exceeds the development of urban employment opportunities. Various forms of legislation have been used to curb subdivision in Europe, and agricultural planners have resorted to extensive and expensive land realignment and consolidation schemes. Quite naturally, therefore, Western agricultural economists have viewed with alarm, the practice of some Asians to own plots jointly, in fractional shares such as 1/2, 1/10, or even 1/1,440.¹ Considering the small size of most cadastral plots (usually under two hectares) in wet-rice growing areas, it could only be assumed that operating the tiny shares must be highly inefficient. The fact is, unknown to Europeans, Chinese do not try to cultivate their tiny legal shares, but use joint landownership as an avenue to consolidate operational units as well as ownership units.

Discovering these consolidation techniques was, for the author, entirely dependent upon use of the cadastral map. In order to elucidate the role of the map, however, it is first essential to examine the process by which joint landownership in Chulin Village leads to consolidation for operation and ownership.

As indicated, joint landownership means that two or more people own a single cadastral plot in undivided fractional shares (Figures 1 and 2). In Chulin Village the plots vary from 0.0064 hectare to 2.9282 hectares in size, while fractional shares range from 1/2 to 1/96.² Shareholders are not always relatives. Moreover, in this system of ownership, no co-owner, not even the largest shareholder, has pre-emptory rights over any given location within the plot. This is important to wet-rice farmers, in that irrigation canals are often adjacent to only one small part of the cadastral plot and everyone enjoys legal rights to the land immediately adjoining the canal and water therefrom. If one co-owner works land distant from the irrigation canal the other co-owners are obliged to provide him with water from the canal (Figure 3). With their legal rights to water secured it remains only for the co-owners to settle among themselves who will cultivate which part of the plot.

Operational consolidation occurs when a group of people jointly own shares in two or more cadastral plots (Figures 4 and 5). Instead of operating their legal shares inside each scattered plot, however, they allocated whole plots or parts of plots to one another for cultivation (Figures 6 and 7).

[Dr. Vander Meer is Assistant Professor, Department of Geography, California State University, Fresno. Presented to WAML Membership Meeting, Fresno, May 11, 1974.]

The area cultivated by each co-owner is equal to the aggregate area he owns in all the jointly owned plots.

Consolidation for ownership occurs when one or more of the joint owners relinquishes his legal rights to an existing owner or they all sell to an outside party. This happens upon death, when people move away or pursue other occupations, or when other land is acquired, thus obviating the need to continue joint ownership.

One may well ask the significance of these two types of consolidation. In fact, in Europe, where unirrigated farming prevails, joint ownership is virtually unknown, and where individual landownership obtains, responsibilities for each plot are not shared. This means that each landowner cultivates the land himself, leases it, or sells it, if inconveniently located. Moreover, once subdivision for individual ownership has taken place there is little if any likelihood for amalgamation with adjacent plots. Thus, in Europe, subdivision increases dispersal and agricultural inefficiency, and agriculturalists are anxious to curb the processes of subdivision. In Taiwan, on the other hand, subdivision by joint ownership can lead to consolidation and therefore it becomes an avenue to agricultural development instead of deterioration.

My own research into the relationship between landownership and consolidation for operation actually began through an intended analysis of farm fragmentation in a Taiwanese village. With the aid of the cadastral map, however, the focus of the study changed markedly. Ultimately, this research tool became instrumental in revealing a phenomenon of far reaching import. The evolution of the research process is an interesting one.

Preparation for the study had revealed that J. L. Buck had found that farms on the China Mainland before 1949 contained an average of 5.4 noncontiguous plots, and in Taiwan A. F. Raper had found the average to be between 9 and 14.³ With such figures as a base, my research efforts were originally directed toward finding whether labor inputs and/or agricultural production declined with increasing dispersal of the farmers' holdings. In scouting for a village in which to conduct the study, however, I was constantly informed by farmers that they held land in one, two, or three places, and only rarely, in five, six, or more locations. Needless to say, these findings did little to enhance the project. At the time, however, I suspected that the farmers were being intentionally deceptive in order to conceal properties unregistered for taxation. I was unaware that the land property records and cadastral surveys in Taiwan are among the most accurate in the world, dating back to 1900, and covering all the agricultural lowlands.⁴

Having selected Chulin Village for concentrating my efforts on the fragmentation problem, I first worked toward indentifying the farmers with the greatest degree of plot dispersal. To my consternation, however, in innumerable cases the land records showing legal property units did not conform to the units which the farmers were actually operating. Many farmers did not work land in the plots in which they owned rights. Others worked all or large parts of plots in which they owned only small shares.

Why, I wondered, were there constant discrepancies between record and reality? Again, I surmised attempts at concealing land and continued on the proposed course. As time became shorter, however, I decided to ignore the ownership problem and to simply survey the labor put into 274 fields in five scattered locations at differing distances from the nucleated cluster of farmsteads. In addition to this labor input survey, I had the official landownership records copied, and by interviewing every head-of-household in the village, compiled a map of actual operational units. In this manner, I hoped that by the conclusion of the field research period I would at least have labor input data plus the operational and legal holdings for every farmer in the village, even though the precise relationship between the latter was as yet unclear.

It was in the analysis of the accumulated data that the cadastral map began assuming its great importance. Labor input data, and ownership and operational units were subjected to countless hours of scrutiny, until finally a cadastral map colored to show the number of owners per plot was by chance compared with the map of plots actually operated by the farmers. Here, for the first time, was revealed the correlation between multi-owner plots and plots not operated by the owners. This discovery led to a review of the people who jointly owned plots, and eventually to finding that the same two, three, four or more people tended to co-own the same plots. From here, it became evident that operational units were rearranged only within the jointly owned cadastral plots, and always in proportion to the amount of land each co-owner had in all the jointly owned cadastral plots. Only gradually over a two year period after leaving Taiwan, then, did it become evident that joint landownership was being used as an avenue to consolidate for operation.

Considerably more time was consumed in finding that joint landownership led to cadastral plot amalgamation, i.e., the re-consolidation of the cadastral plot back to individual plot ownership. While this was readily apparent from the land records, which indicated periods of individual and then joint ownership, the full importance of the role of joint landownership became evident only after the compiling of a chronological chart, which indicated that 55-65% of all cadastral plots which had been jointly owned had experienced amalgamation (Figures 8 and 9). Clearly, joint ownership was being used as a strategy to temporarily avoid the binding finality of individual ownership.

Ultimately, the research shows that for the developing nations, where funds do not exist for planning an/or implementing major land consolidation schemes, joint landownership provides a feasible avenue to delaying and even avoiding the agriculturally deleterious affects of dispersal and subdivision. In arriving at this conclusion, the cadastral map had proven to be a critical catalyst amidst masses of frequently conflicting data, and a tool which future researchers on agricultural development can little afford to ignore.

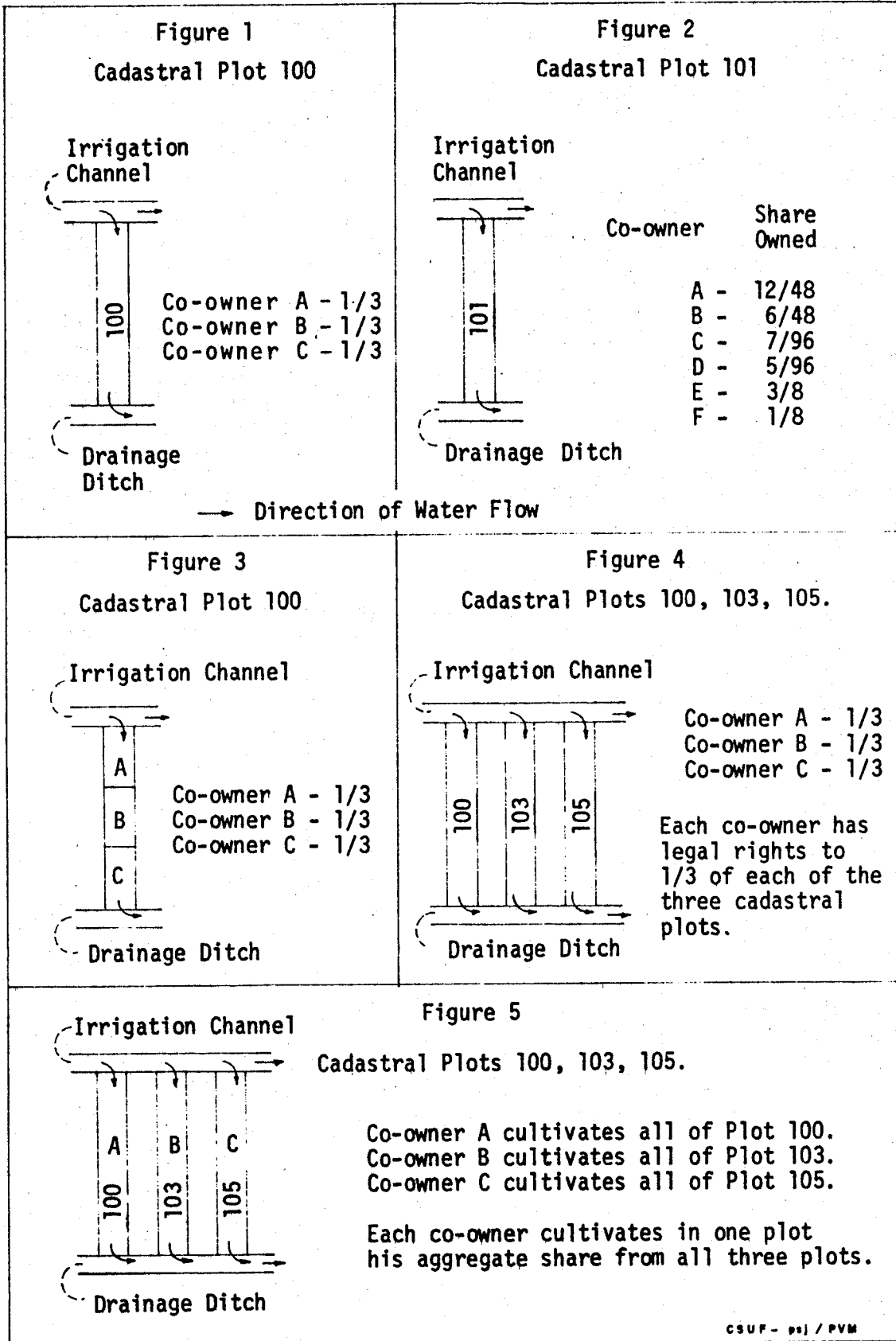
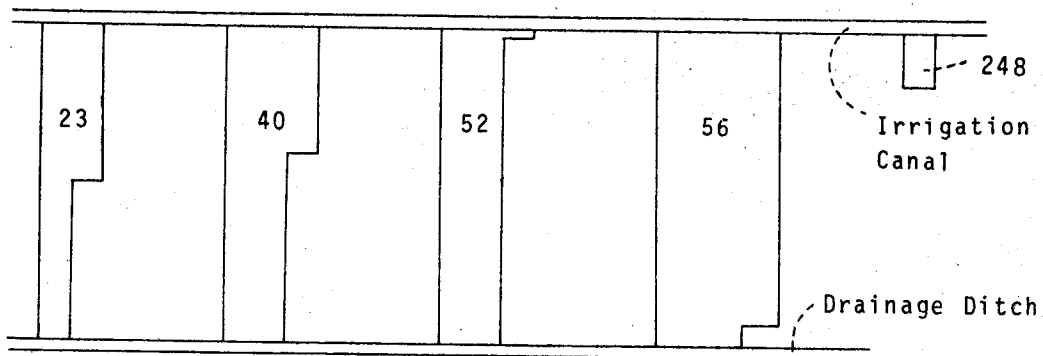
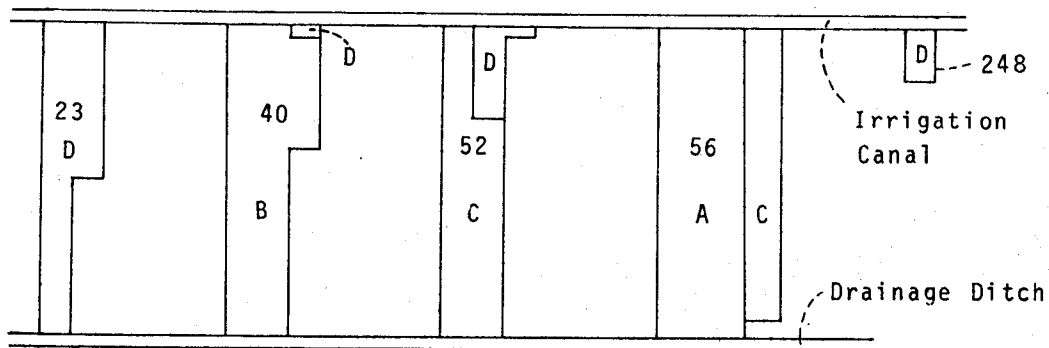

Figure 6



Plot Number	Plot Size (Hectares)	Co-owners' Fraction and Hectareage			
		A	B	C	D
23	0.5054	95/260 0.18472	10/260 0.01941	77/260 0.14965	78/260 0.15162
40	0.8136	55/170 0.26323	115/340 0.27519	115/680 0.13759	115/680 0.13759
52	0.6910	250/3455 0.05000	250/3455 0.05000	2155/3455 0.43100	800/3455 0.16000
56	1.3316	1/3 0.44387	1/3 0.44387	1/6 0.22193	1/6 0.22193
248	0.0586	1/5 0.01172	1/5 0.01172	1/5 0.01172	2/5 0.02344
Aggregate Hectareage Owned		0.95354	0.80019	0.95189	0.69458

Figure 7



Plot Number	Plot Size (Hectares)	Hectareage Operated by Each Co-owner			
		A	B	C	D
23	0.5054	-	-	-	0.5054
40	0.8136	-	0.80019	-	0.01341
52	0.6910	-	-	0.57383	0.11717
56	1.3316	0.95354	-	0.37806	-
248	0.0586	-	-	-	0.0586
Aggregate Hectareage Operated		0.95354	0.80019	0.95189	0.69458

Figure 8.

CHRONOLOGY OF CADASTRAL PLOT TRANSFERS - PADDY LAND ONLY
CHULIN VILLAGE, TAIWAN
1900 - 1967

- 1. Each horizontal line represents a single owner.
- 2. Two or more closely spaced parallel lines represent multiple ownership, i.e., joint land ownership.
- 3. Vertical slashes indicate change of owner (initiation or termination).
- 4. Dashed line indicates exact owner unknown.
- 5. Only cadastral plots in which Chulin residents held ownership in 1967 are included.
- 6. Data for the years 1900-1902 and 1967 are incomplete.

PART 1 of 2

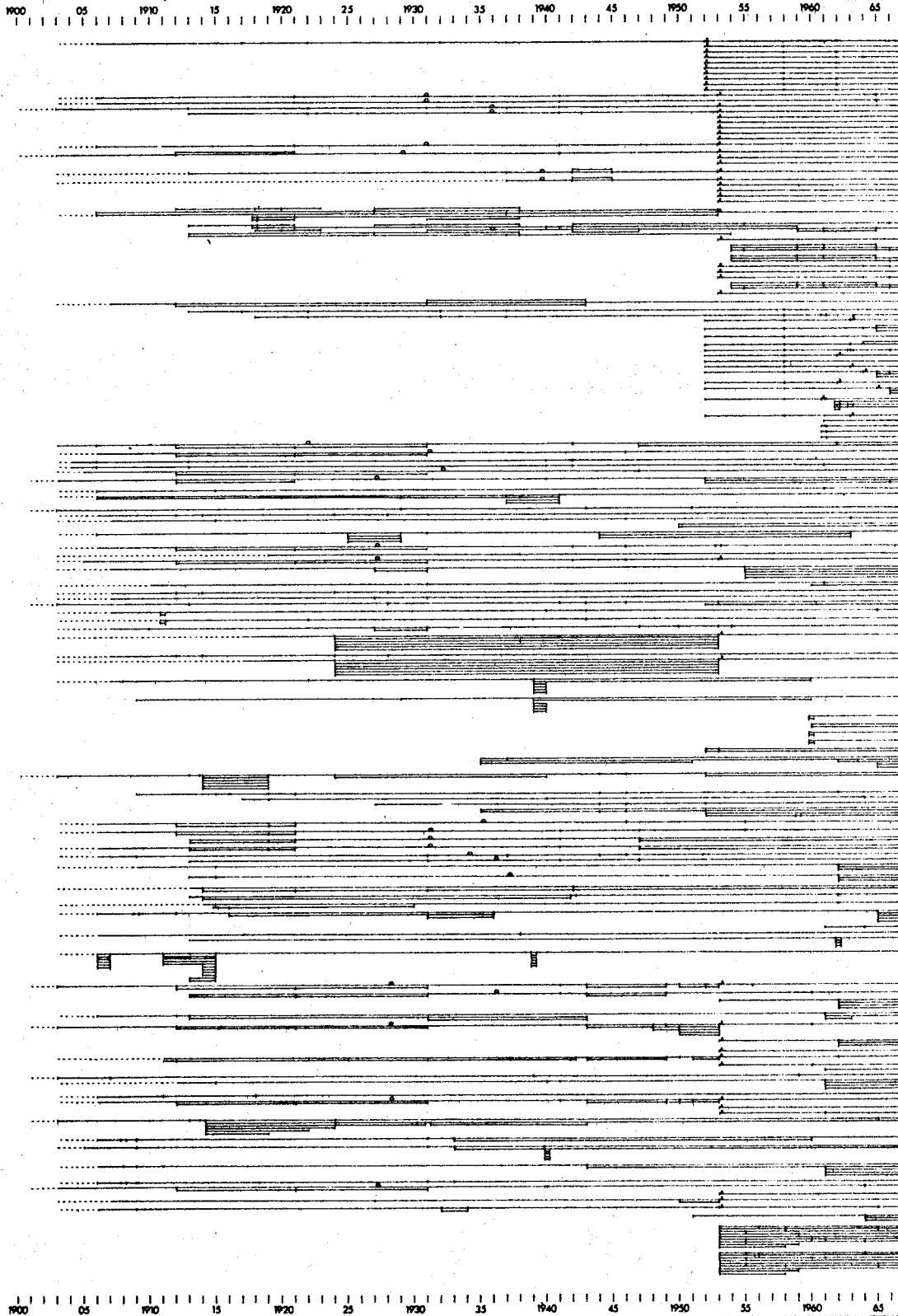

PJM

Figure 9.

CHRONOLOGY OF CADASTRAL PLOT TRANSFERS - PADDY LAND ONLY
CHULIN VILLAGE, TAIWAN
1900-1967

- 1. Each horizontal line represents a single owner.
- 2. Two or more closely spaced parallel lines represent multiple ownership, i.e., joint land ownership.
- 3. Vertical slashes indicate change of owner (initiation or termination).
- 4. Dashed line indicates exact owner unknown.
- 5. Only cadastral plots in which Chulin residents held ownership in 1967 are included.
- 6. Data for the years 1900-1902 and 1967 are incomplete.

PART 2 of 2

1900 05 1910 15 1920 25 1930 35 1940 45 1950 55 1960 65

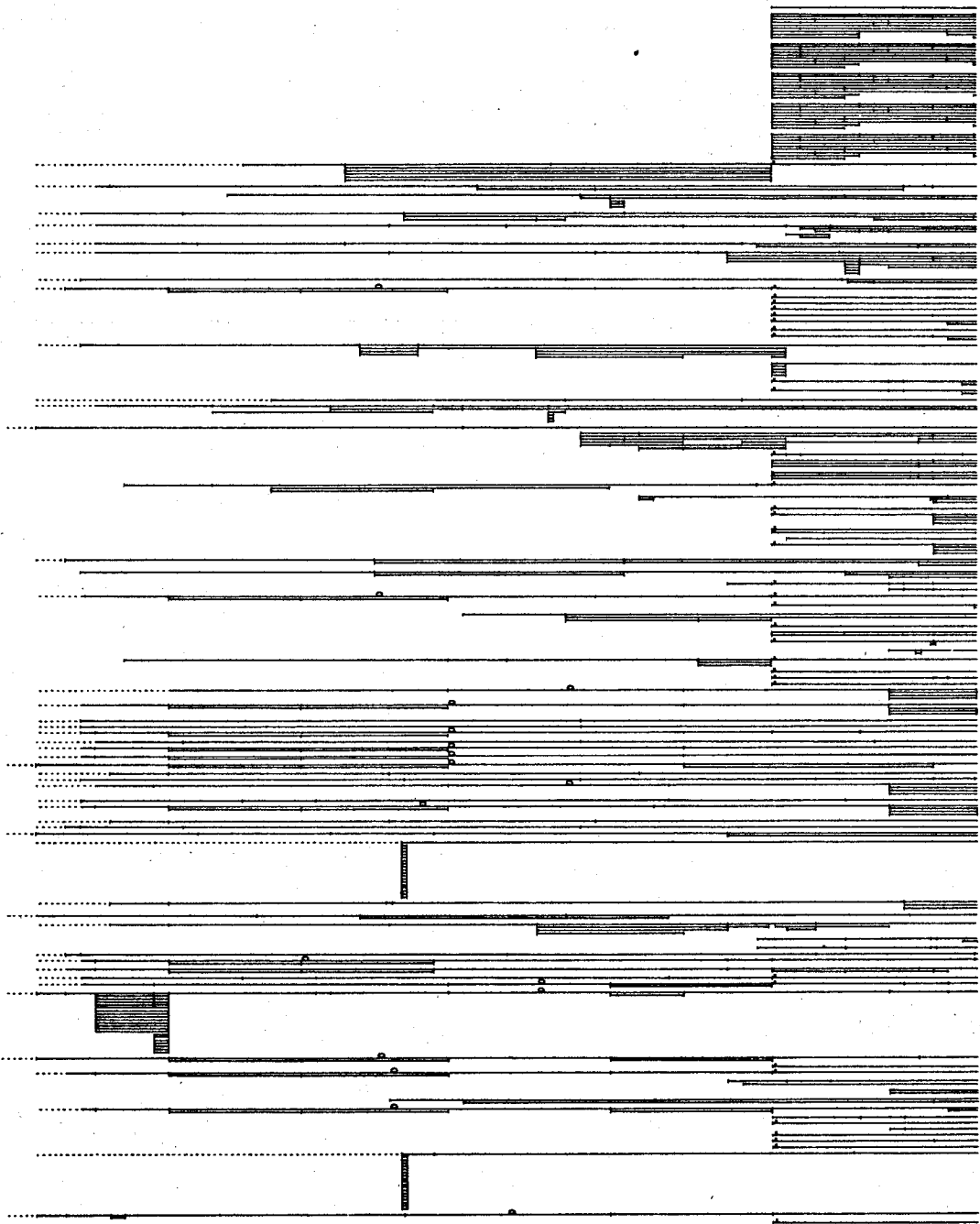

1900 05 1910 15 1920 25 1930 35 1940 45 1950 55 1960 65

PSJ
L.C.
P.V.M.

FOOTNOTES

¹L. A. Peter Gosling, "Fragmentation and Consolidation of Agricultural Land in Malaya" (paper presented at the Nineteenth International Geographical Congress, Stockholm, July, 1960).

²Paul Vander Meer, "Farm Plot Dispersal, Luliao Village, Taiwan, 1967" (unpublished Ph.D. dissertation, University of Michigan, 1973), pp. 202 and 308-345. Luliao is the colloquial name for Chulin.

³John L. Buck, Land Utilization in China (Shanghai: North China Daily News, 1937), pp. 181-185; Arthur F. Raper, Rural Taiwan -- Problem and Promise (Taipei: Chinese-American Joint Commission on Rural Reconstruction, 1953), p. 147.

⁴Canute and Paul Vander Meer, "Land Property Data on Taiwan," The Journal of Asian Studies, November 1968, pp. 144-150.

NEW WAML MEMBERS AND SUBSCRIBERS

[Since similar listing in Information Bulletin, Vol. 5, #2, p.4-6.]

NEW INSTITUTIONAL MEMBERS

Department of Geography
California State University
San Diego, California

Woods Hole Oceanographic Institution
Attn: William M. Dunkle
Data Library, D.E.S.C.
Woods Hole, Massachusetts

NEW EXCHANGE MEMBER

IREBI - Indices de Revistas de Bibliotecologia
Centro de Documentacion Bibliotecologica
Avda. Alem 1253
Bahia Blanca, Argentina

NEW ASSOCIATE MEMBERS

Mrs. Gwendolyn R. Barckley
SUNY Agricultural & Tech Coll
Greenley Library, Reference Dept.
Farmingdale, New York

Peter D. Brown
Cartography Department
Ministry of the Environment
Toronto, Canada

NEW ASSOCIATE MEMBERS (continued)

Brad Fay
Head, Information Centre
Maritime Resource Management Service
Amherst, Nova Scotia, Canada

Janice T. Fitzpatrick
U.S. Geological Survey
Reston, Virginia

June C. Harris
University of Georgia
Science Library, Map Collection
Athens, Georgia

Janet Swan Hill
U.S. Library of Congress
Geography and Map Division
Reston, Virginia

Betty Kidd
Acting Head, National Map Collection
Public Archives of Canada
Ottawa, Canada

Alberta G. A. Koerner
Chairwoman, Geography & Map Div. SLA
Detroit Public Library
Detroit, Michigan

NEW ASSOCIATE MEMBERS (continued)

David C. McQuillan
Map Depository, Dept. of Geography
University of South Carolina
Columbia, South Carolina

Roger P. Nason
New Brunswick Provincial Archives
Fredericton, New Brunswick, Canada

Karl H. Proehl
SUNY at Stony Brook
Map Library
Stony Brook, Long Island, New York

Daniel T. Seldin
Geography & Map Librarian
Indiana University
Bloomington, Indiana

Marsha L. Selmer
Library Map Section
University of Illinois
Chicago, Illinois

Barbara P. Tiberio
SUNY at Binghamton
Map Room Science Library
Binghamton, New York

NEW SUBSCRIBERS

Department of Library Science
Ball State University
Muncie, Indiana

Staatsbibliothek
Preussischer Kulturbesitz
Kartenabteilung
Berlin, Germany

British Library
Lending Division
Yorkshire, England

General Library
British Museum (Natural History)
London, England

California Polytecnic State University
Library
San Luis Obispo, California

NEW SUBSCRIBERS (continued)

11

University Library
Cambridge, England

The Library
Evergreen State College
Olympia, Washington

Institute of Geological Sciences
London, England

College of Library and Information
Services, Library
University of Maryland
College Park, Maryland

Baillieu Library
University of Melbourne
Parkville, Victoria, Australia

The Newberry Library
Chicago, Illinois

Queensland Institute of Technology
Brisbane, Australia

Rand McNally & Co.
Chicago, Illinois

Rosary College
River Forest, Illinois

McKissick Library
University of South Carolina
Columbia, South Carolina

Rochelle A. Stephens
Topographic Center, Defense Mapping Ag.
Washington, D.C.

Metropolitan Toronto Central Library
Toronto, Canada

U.S. Central Intelligence Agency
Washington, D.C.

NEW INDIVIDUAL MEMBERS

Larry Cruse
University Library
University of California
San Diego, California

NEW INDIVIDUAL MEMBERS (continued)

Robert B. Fisher, MD
Fremont, California

Dan Gardner
Graduate Geography Student
Fullerton, California

George Ilinsky
[Arizona State University,
Hayden Library, Map Collection]
Phoenix, Arizona

Harrison Kimball
Los Angeles, California

Robert E. Lee
Los Gatos Historical Society
Los Gatos, California

Gene D. McPherson
Bureau of Engineering
Street Opening & Widening Division
City of Los Angeles
Los Angeles, California

John Newman
Special Collections
Colorado State University Libraries
Ft. Collins, Colorado

Ronald D. Smith
Benicia, California

Totals as of October 22, 1974

Individual Members: 87

Associate Members: 38

Institutional Members: 22

Subscribers: 96

Exchanges: 9

Total mailing list: 252

One forthcoming Membership worthy of
special note: [our first from Africa]

Gilbert H. Chikwapulo
Map Librarian
Chancellor College
Department of Geography & Earth
Sciences
University of Malawi
Zomba, Malawi

NEW DEVELOPMENTS IN PROMOTION OF WAML & Information Bulletin

The Information Bulletin Editor has replied to a request from the Federation Internationale de Documentation (FID), The Hague, Netherlands. The FID, under a contract with UNESCO, is compiling the fourth edition of Library and Documentation Journals. The questionnaire included information regarding publishing data, history and frequency data, subscription price, contents, etc.

The Publications Advisory Committee, and the WAML Executive Committee, have agreed to exchange publications with the Centro de Documentacion Bibliotecologica, Bahia Blanca, Argentina, who, together with the Instituto Bibliografico Hispánico and the Oficina de Educación Iberoamericana (Madrid) plans to include the Information Bulletin in its indexing. Their new publication (1973) includes contents of journals of Librarianship, Information Science and Documentacion; it is called IREBI. (*Indices de Revistas de Bibliotecologia*)

Your Editor has also prepared a full-page description of WAML and its publications for inclusion in CARTINFORM, the annotated information service issued with CARTACTUAL, the bi-monthly topical map service publication of Budapest, Hungary.

by

Harold M. Otness
Southern Oregon College
Ashland, Oregon

Map folding is a joke, and probably one of the most repetitious and tiresome jokes a map librarian encounters. Yet it is a topic worthy of serious consideration as well, and perhaps it is time that just such an account finds its way into the professional literature of map librarianship.

There are innumerable ways in which maps are folded, and each has its advantages and drawbacks. The method of folding should depend upon the size of the map, the use to which the map will be put, the arrangement of the material on the map itself, and other factors as well.

Methods of folding maps, and the machines that do it, are patentable. It has been estimated that there are somewhere in the neighborhood of a hundred styles under copyright in the world today (Ristow, 636). The literature of this fascinating topic is buried in the patent records and in the trade publications of the printing industry. There has been a single excellent article emphasizing the technical aspects, translated from German, which appeared in a cartographic publication sixteen years ago (Mülhe). And while there is an abundance of information concerning how to use maps, there appears to be little written advise on how to refold them when finished.

The Methods

Although maps are folded in a number of ways (and refolded in even more), they can be grouped into four basic categories, with a fifth added to include miscellaneous curiosities. The terminology appears to be more confusing than the methods themselves. Some of the terms used below are of the author's invention simply because no standard terms could be found.

NO APPARENT METHOD FOLD. While most maps are folded according to some preconceived plan, some, especially those issued by non-specialized printers and publishers, appear to have no overall pattern whatsoever. These maps are apparently folded in response to the convenience of the folding equipment: the quickest and cheapest method is used. These are the most awkward maps to refold because there is no logic to their folding pattern. They must be refolded in whatever irrational way they were originally folded.

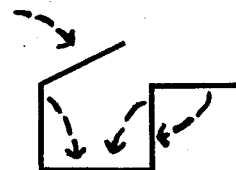

Examples of No Apparent Method Folds

STANDARD FOLD. This is my term for maps which are doubled over and creased, usually on the short dimension, folded in half again, this time probably at right angle to the first fold, and so on until the desired size is reached.

This is the simplest and most obvious folding method.

The standard fold is often used for very large maps and especially for those oversized maps which are bound into volumes. Some, but not all, maps of the National Geographic Society are folded in this manner. It is a method best suited for those maps which will be observed in their entirety because in most cases the map has to be completely unfolded in order to view any portion of it. If the printing is on one side only, and the map is folded inward, no part of it will be revealed until the last fold is opened. Consequently portions of it cannot be quickly and easily consulted.

Maps folded in this manner are prone to tear along their creases, particularly when bound in volumes. Thus they must be handled with some care. They can be troublesome to refold because their creases change orientation as they pass through creases crossing them at right angles. Only the first fold keeps its orientation from edge to edge. Standard fold maps must be refolded in their proper sequence to avoid disaster.

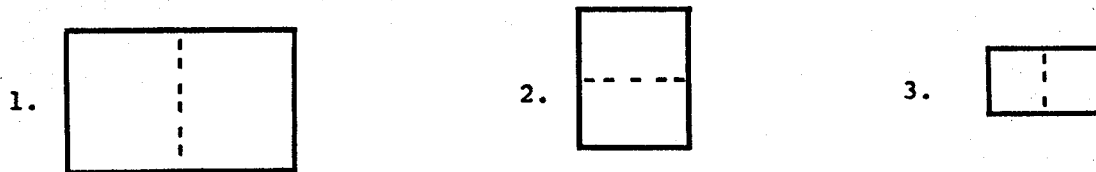

Example of a Standard Fold

CONCERTINA FOLD (also called Leprello, accordion, and sometimes pleated). Maps folded in this manner have creases which maintain their folding direction from edge to edge, with every other crease turning the same way. The map is pulled out completely in one dimension before it is opened from the other. In other words, the map is opened just like the bellows of an accordion. Sometimes maps are folded concertina style in both dimensions, but more often just in the longest dimension.

The major advantage of concertina style is that it permits various portions of the map to be viewed without opening the map completely. Thus it is well suited for the motorist who is driving sixty-miles-per-hour in heavy traffic and wants to check his position on the map. He may only have to open one crease to view the area he desires. It is also convenient for the hiker and field worker because on a rainy or windy day there is no need to get the entire map wet or turn it into a sail. Another advantage of the concertina fold is that it is easily refolded.

Most American road maps incorporate the concertina fold or variations of it. There is a concertina fold in which each section or pleat is of a narrower width than the adjoining one. A map folded with these tapered pleats is almost impossible to refold improperly: if done wrong the creases simply won't match.

There are many interesting and elaborate applications of the concertina fold. Rand McNally in this country has used it extensively as has Mairs Geographischer Verlag in Germany. The Almax plan of Madrid has three separate tapered maps glued back to back. Thumbing for the desired pleat may take a minute but during the process you will be refreshed by the fanning effect.

*Concertina Fold**Tapered Concertina**(Side Views)*

CUT-FOLD. These maps have been cut along one or more creases so as to permit a section of the map to be opened while leaving the remainder folded. There are side cuts which come in from the outside edges, and interior slits. The map can still be completely unfolded, of course, but the slits will remain. The folds themselves are usually concertina or some variation of it. Cut-fold maps are almost always enclosed in covers of some sort to prevent the slits from cutting and tearing.

Cut-folds are best seen on some European city plans designed for tourist use. The German Falkplans incorporate some highly ingenious cut-folds in which as many as half-a-dozen sections may be unfolded independent of each other. Some sections are separate maps at their own scales. Particularly careful planning is needed when both sides of the paper is printed. Cut-folds are subject to tearing when the paper is not strong.

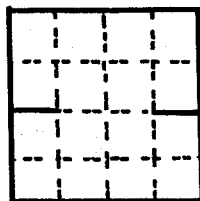
*Side Cuts*

*(solid lines are
cuts; dotted
lines are folds)*

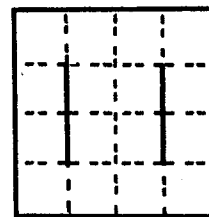
*Interior Cuts*

MISCELLANEOUS FOLDS. The possibilities for map folds are endless. Maps don't have to have right angle folds exclusively. Diagonal folds can be used to achieve a triangular folded shape. Nor do maps have to be square or rectangular to begin with. The earth itself is round and many of the features on it are more circular in shape than they are square. A round map can be folded like pieces of pie, or folded towards the center to produce a small octagon.

Some of the more dramatic folds are those which are designed to pop-up when their covers are opened. Perhaps the inspiration for these is origami. Examples of these known to the author include a "Convention Fun Map" of Reno and a map of Guatemala City issued by the Dirección General de Turismo. The latter is a pop-up round plan in which the important public buildings are illustrated around the outer edge. The inside cover, which is rectangular, contains the legend.

There are no doubt many examples of unconventional map folds. This intriguing topic is wide open for investigation.

Coordinating the Folds with the Map Information

Not only is the method of folding an important consideration in map making, but the placement of the folds themselves is something that should not be left to chance. Folds should not divide information that is best viewed as a whole, such as indexes, legends, and focal points. For example, a highway map of Oregon that is well planned will not have a fold running through Portland. Insets of areas at different scales from the main map are most effectively viewed when not divided by creases. In fact the crease itself forms a logical boundary for a change in scale or format.

Most American road maps are designed with these considerations in mind, and the final product is so effective that the user is probably not often aware of the planning that has been involved. But when the arrangement of the map material and the folds are not coordinated, the results can be most irritating to the map user.

A Word on Refolding Maps

A map should be refolded in the manner in which it was initially folded. It is essentially just a matter of "reading the creases". First look for the major creases which are continuous across the sheet without changing folding direction. The concertina folds are all major folds in this respect and they are easily spotted. In other folding styles the creases must be read more carefully because they will change folding direction across the sheet. With the standard fold, each fold reduces the map by half: just keep folding and turning the map to find the next crease. The cover sections are give-aways - they should end up on top.

It is all really very simple except when the map has been improperly refolded in the past or pressed out flat so that the creases fail to indicate the proper folding direction. There may even be a few new creases to confuse the issue. Here you are reduced to guessing. You can try a standard fold or a concertina fold. You can speculate on whether the cuts are there by design or by wear and tear.

And you can think about all those old map folding jokes, which really aren't very funny at all.

Bibliography

Mülhe, Helmut. "The Folding of Maps". in Second International Cartographic Congress, Chicago, 1958. Published by the American Congress on Surveying and Mapping, Cartographic Division, Series II, no. 7, pp. 55-69. (Abridged reprint and translation from Polygraph, 1958, Frankfurt a.m.)

Ristow, Walter W. "A Half Century of Oil Company Road Maps". Surveying and Mapping. 24:617-37, 1964.

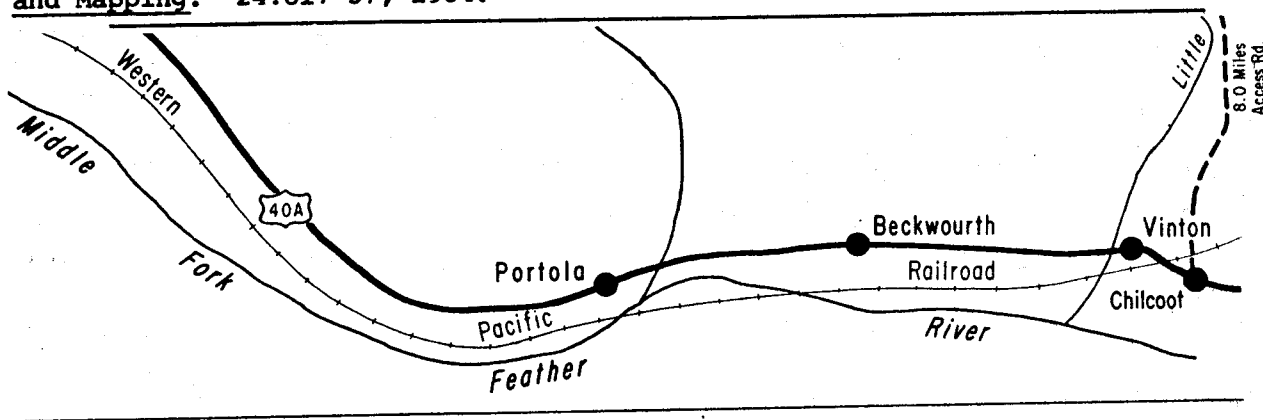

ATLASES CATALOGED AT UCLA

by

Anna F. Blustein
Associate Librarian (Cataloger)
University Research Library
University of California, Los Angeles

GEOGRAPHICAL MYTHS

Post, Jeremiah B.

An atlas of fantasy. Compiled by J.B. Post. Baltimore, Mirage Press, 1973. xi, 283 p. (chiefly maps)
Maps are facsimiles.

1. Geographical myths - Maps. 2. Fantastic literature - Maps. \$20.00

MOON

The Times atlas of the moon. Edited by H.A.G. Lewis. London, Times Newspapers Ltd. [1969]
xxxvii p., 110 p. of col. maps, col. illus. 35 cm.

Compiled from maps produced by the U.S. Aeronautical Chart and Information Center.

1. Moon - Maps. I. Lewis, H.A.G. II. U.S. Aeronautical Chart and Information Center, St. Louis. III. The Times, London. IV. Title: Atlas of the moon.

WORLD

Elsevier, Uitgevers Maatschappij, N.V. Geografisch en Cartografisch Instituut.

Grote Winkler Prins atlas. [Algemele leiding: A.F.J. Wubbe. Redactie: R. Berkenbosch. Adviseur: A.J. Wiggers. Medewerking: M. Bierman, A. Galema, W. de Gans, e.a.] Amsterdam, Elsevier, 1972.

340 p. col. illus., col. maps. 38 cm.

Issued in box, with six folded, colored facsimile "Karten uit de eerste 'Moderne' atlas, Theatrum Orbis Terrarum (1570) van Abraham Ortelius" in pocket.

1. Atlases, Dutch. I. Title. II. Title: Winkler Prins atlas.

WORLD (continued)

Encyclopaedia Britannica.

World orientation atlas; a global desk study unit. Student ed. New York, distributed by C.S. Hammond [1946?]

[32] p. (incl. covers) illus., maps. 42x32 cm.

Cover title. Additional text on covers.

Kinnear, William

Exploration universe; an atlas of our environment. Edited by William Kinnear and James R. Carson. Edinburgh, Bartholomew, 1972.

47 p. col. illus., col. maps. 31 cm.

1. Atlases, British. 2. Man - Influence of environment.

Nayman, Jacqueline.

Atlas of wildlife. Illustrated by Adrian Williams and David Nockles. Maps by Geographical Projects, London. Consultant: Maurice Burton. New York, John Day Co. [1972]

124 p. col. illus., col. maps. 31 cm.

1. Zoogeography. \$10.00

Oxford University Press.

Oxford World atlas. Edited by Saul B. Cohen. New York, Oxford University Press, 1973.

xii, 190 p. (chiefly col. maps) 38 cm.

1. Atlases, British. I. Cohen, Saul Bernard. II. Title. \$19.95

Gohm, Douglas Charles.

Antique maps of Europe, the Americas, West Indies, Australasia, Africa, the Orient [compiled] by Douglas Gohm. London, Octopus Books [1972]

128 p. chiefly maps (some col.). 33 cm. Index. £2.50

1. Maps, Early - Facsimiles. 2. Cartographers - Biography.

WORLD (continued)

Dèttore, Ugo

Atlante storico per la scuola media. Novara, Istituto geografico De Agostini [1965-

v. col.illus.,col.maps. 30 cm. Contents.- v.1. Dalle antiche civiltà ai regni romano-barbarici.- v.2. Dai regni romano-barbarici al congresso di Vienna.- v.3. Dai congresso di Vienna a oggi.

1. Geography, Historical - Maps.

Gilbert, Martin, 1936-

Jewish history atlas. Cartography by Arthur Banks. [1st American ed. New York] Macmillan [1973,c1969]

112 p.of maps.,[14] p. 24 cm.

"First American edition 1969; second printing 1973." Bibliography: p.[126]-[131]

1. Jews - Historical geography - Maps.
2. Israel - Historical geography - Maps. I. Banks, Arthur. II. Title.

Gilbert, Martin, 1936-

First World War Atlas. 1st American ed. New York, Macmillan 1971,c1970.

170 maps.

Banks, Arthur

A world atlas of military history. With an introd. by Lord Chalfont. New York City, Hippocrene Books [1973- v. maps.

Contents.- v.1. To 1500.- [No indication of ultimate number in this series of atlases.] \$12.95

1. Military history - Maps.

Hawes, Gordon K

Atlas of man and religion; designed and compiled by Gordon K. Hawes, layout and maps by Stanley Knight. [Oxford, New York] Religious Education P. [1970] 127 p. illus.,col.maps,ports. 28 cm.

1. Ecclesiastical geography - Maps. I. Knight, Stanley.

Jarman, Catherine.

Atlas of animal migration. Illustrated by Peter Warner & Tony Swift. Maps by Geographical Projects, London. Consultant: Michael Boorer. New York, John Day Co. [1972] \$10.00

124 p. col.illus.,col.maps. 31 cm.

1. Animal migration. 2. Zoogeography.

Johnson, Hugh, 1939-

The world atlas of wine; a complete guide to the wines & spirits of the world. New York, Simon and Schuster [1971]

272 p. illus.(some col.), col.maps. 30 cm. "4th prtg."

1. Wine and wine making. \$29.95

Kremling, Ernst, 1901-

JRO Weltwirtschafts-Atlas; Atlas für Politik und Zeitgeschichte. Permanente Ausg. Herausgeber: Ernst Kremling; Bearbeiter: G. Fochler-Hauke. München, JRO-Verlag [1957-

3 v. (loose-leaf) maps (part fold., part col.) diagrs., tables. 31 cm. Kept up to date by loose-leaf replacements and additions.

1. Geography, Economic - Maps. 2. World politics - Maps. 3. Atlases, German. I. Fochler-Hauke, Gustav, 1906-

Oxford University Press

Oxford economic atlas of the World. [London, 1973,c1972] 4th edition, reprinted 1973.

viii,239 p. col.illus., col.maps, tables. 39 cm.

1. Geography, Economic - Maps. I. Economist (London). \$25.00

Richason, Benjamin F.

Atlas of cultural features; a study of man's imprint on the land. [Northbrook, Ill.] Hubbard Press [1972]

96 p. illus.,col.maps. 29 cm.

Includes 36 colored maps, each with a corresponding aerial photograph.

1. Land utilization - United States - Maps. 2. Man - Influence on nature - Maps. 3. Photographic interpretation.

WORLD (continued)

Wilson, Andrew, 1923-

The 'Observer' atlas of world affairs: a guide to major tensions and conflicts, edited by Andrew Wilson. Visual aids by Diagram. London, G. Philip, 1971.

111 p. illus.(some col.), maps (chiefly col.). 29 cm. £2.50

1. World politics - 1945 - Maps. 2. Geography, Historical - Maps.

World atlas of shipping: Sea and shipping, edited by W.D. Ewart. World atlas, edited by H. Fullard. New York, St. Martin's P. [1973]

[vii], 64, 128, 83 [i.e. 84] p. illus. (chiefly col.), col. maps (p. 1-128) 29 cm.

Maps by George Philip and Son, Ltd.

1. Ocean - Maps. 2. Shipping. 3. Atlases, British. I. Ewart, William Dunlop. \$22.50

Russia (1923- U.S.S.R.) Voenno-morskoe ministerstvo.

Morskoi atlas. Edited by Ivan Stepanovich Isakov, and L. A. Demin. Moscow, Ministerstvo oborony, 1950-58.

3 v. col. maps (part fold.) 52 cm.

Index to geographical names in v. 1. Vols. 1-3 issued in portfolios. Description of maps in v. 3, pt. 1.

1. Ocean - Maps. 2. Harbors - Maps. 3. Geography, Historical - Maps.

[see entry in *Publications of Relevance*, this issue, under Dubach, Harold W. for "An evaluation of the "Morskoi atlas".

NORTH AMERICA

Clement, Roland C.

Hammond nature atlas of America, by Roland C. Clement. Photographers: Erwin A. Bauer [and others] Maplewood, N.J., Hammond [1973]

255 p. col. illus., col. maps. 32 cm. Bibliography: p. 251.

1. Natural history - North America.

CANADA

Belden (H.) and Company.

Illustrated atlas of the Eastern Townships and South Western Quebec. [Toronto] 1881. Reprint ed. Port Elgin, Ont., R. Cumming, 1972.

88 p. illus., maps, ports. 46 cm.

"Reprinted from the Belden Dominion of Canada atlas of 1881 which was prepared for the Eastern Townships and Southwestern Quebec region." Material not directly related to Quebec has been omitted. Sketches from the Belden Lanark and Bruce atlases which belong to Quebec, but were left out of the Eastern Township atlas, have been added.

Cover title: Historical atlas of Quebec Eastern Townships; illustrated.

1. Eastern Townships, Quebec - Maps. 2. Quebec (Province) - Maps. 3. Real property - Eastern Townships, Quebec - Maps. 4. Real property - Quebec (Province) - Maps. 5. Eastern Townships, Quebec - History. 6. Quebec (Province) - History.

Belden (H.) and Company.

Illustrated historical atlas of the county of Carleton (including city of Ottawa) Ont. Compiled, drawn and published from personal examinations and surveys, by H. Belden & Co. Toronto, 1879. [Port Elgin, Ont., R. Cumming, 1971]

1v, 48 p. illus., maps, ports. 46 cm. \$12.50

Cover title: Historical atlas of Carleton County, Ontario; illustrated. Facsimile of the 1879 ed.

1. Carleton Co., Ont. - Maps. 2. Real property - Carleton Co., Ont. - Maps. 3. Carleton Co., Ont. - History.

Canada. Surveys and Mapping Branch. Atlas and gazetteer of Canada. [Ottawa] Dept. of Energy, Mines and Resources, Surveys and Mapping Branch [1969]

104 p. col. maps (p. 6-53) 38 cm.

1. Canada - Maps.

CANADA (continued)

Larousse, firm, publishers, Paris.

Atlas Larousse canadien, sous la direction de Benoît Brouillette [et] Maurice Saint-Yves avec la participation de Georges Reynaud-Dulaurier. Québec, Editions françaises [1971] viii, 128, 33 p. illus., col. maps (p. 1-128) 29 cm.

Col. maps on lining papers.

1. Atlases, Canadian.

Letarte, Jacques, 1936-

Atlas d'histoire économique et sociale du Québec, 1851-1901. Montréal, Fides [1971]

13 p., 44 fold. illus. (incl. maps) 25 cm. (Histoire économique et sociale du Canada français) \$4.00

1. Quebec (Province) - Economic conditions - Maps.

Meacham (J.H.) & Co.

Illustrated historical atlas of Prince Edward Island. Foreword by the Hon. Alexander B. Campbell. Commemorative centennial issue. Belleville, Ont., Mika Silk-Screening Ltd., 1973.

xvii, 162, [26] p. illus., maps, ports. 46 cm. "Centennial second edition, 1973; edited by Mika Silk Screening Limited, Belleville, Ont."

Facsim. of the 1880 ed., with xvii p. of additional material.

Original t.p. reads: Illustrated historical atlas of the Province of Prince Edward Island from surveys made under the direction of C.R. Allen. [Toronto] J.H. Meacham & Co., publishers, 1880.

1. Prince Edward Island - Maps. 2. Real property - Prince Edward Island - Maps. 3. Prince Edward Island - History. I. Allen, C.R. II. Mika Silk Screening Limited.

Marois, Claude

Atlas de l'emploi, ville et île de Montréal. Employment atlas, city and island of Montreal. Montréal, Les Presses de l'Université du Québec, 1972.

xxiii, 184 p. of maps (2 overlay maps in pocket) 28x38 cm.

1. Montreal metropolitan area - Industries - Maps. 2. Occupations - ...

Mollard, J D

Landforms and surface materials of Canada: a stereoscopic airphoto atlas and glossary. [3d ed.] Regina, Sask. [1973?]

1 v. (loose-leaf) chiefly maps. 29x35 cm. On cover: "A guide to terrain analysis for engineering, geological and environmental studies." Title on spine: "Airphoto interpretation manual." Includes bibliography.

1. Photographic interpretation - Problems, exercises, etc. 2. Aerial photography in geography. 3. Landforms - Canada - Aerial photographs. 4. Canada - Aerial photographs.

Page, H R

Illustrated historical atlas of the counties of Lincoln and Welland, Ont. Compiled, drawn and published from personal examinations and surveys by H. R. Page. Toronto, 1876. [Port Elgin, Ont., R. Cumming, 1971]

88 p. illus., maps, ports. 46 cm.

Provincial maps omitted from this facsimile edition. Cover title: Historical atlas of Lincoln & Welland, Ontario; illustrated.

1. Lincoln Co., Ont. - Maps.

Page and Smith.

Illustrated historical atlas of the county of Wentworth, Ont. Compiled, drawn and published from personal examinations and surveys by Page & Smith. Toronto, 1875. [Dundas, Ont., Dundas Valley School of Art, 1971]

xviii, 63 p. illus., maps, ports. 46 cm.

Historical sketch written by R.K. Kernighan ("The Khan"). On cover: Wentworth Co., illustrated; published by H.R. Page, Toronto, Ont., 1875.

Facsimile of the 1875 ed.

1. Wentworth Co., Ont. - Maps.

Pope, John Henry, 1824-1889.

Illustrated historical atlas of the county of Halton, Ont. Compiled and drawn from official plans and special surveys, by J. H. Pope. Toronto, Walker & Miles, 1877. [Port Elgin, Ont., R. Cumming, 1971]

72 p. illus., maps, ports. 46 cm.

Cover title: Historical atlas of Halton County, Ontario; illustrated. Facsimile of the 1877 ed.

CANADA (continued)

Warkentin, John, 1928- comp.
 Manitoba historical atlas; a selection of facsimile maps, plans, and sketches from 1612 to 1969, edited with introductions and annotations by John Warkentin and Richard I. Ruggles. Winnipeg, Historical and Scientific Society of Manitoba, 1970.
 xvi, 585 p. illus., maps. 31 cm.
 Bibliography: 575-585.

1. Manitoba - Historical geography - Maps. 2. Cartography - Manitoba.
- I. Ruggles, Richard I., 1923 - joint comp.

UNITED STATES

Geraghty, James J
 Water atlas of the United States [by James J.] Geraghty, [David W.] Miller, [Frits] Van der Leeden [and Fred L.] Troise. [3d ed.] Port Washington, N.Y. [Water Information Center, c1973]
 [9] p., 122 pl. (120 col. maps) on [95] p. 24x35 cm.
 "A Water Information Center publication." Text for each map printed on verso of preceding map. Previous editions by D.W. Miller, J.J. Geraghty, and R.S. Collins.

1. Water-supply - United States - Maps.

 Gilbert, Martin, 1936-
 American history atlas; cartography by Arthur Banks. [1st American ed.] New York, Macmillan Co. [1973, c1968]
 [10] p., 112 p. of maps. 24 cm.
 "First American edition 1969"

1. U.S. - Historical geography - Maps.

 Cohen, Philip M 1931-
 An atlas of Long Island's water resources, by Philip Cohen, O.L. Franke, and B. L. Foxworthy. Prepared by the U.S. Geological Survey, in cooperation with the New York State Water Resources Commission. [Albany] State of New York, 1968.

117 p. col. illus., 1 col. map. 22 x 28 cm. (New York Water Resources Commission bulletin 62) Bibliography: p. 111-117.

1. Water-supply-New York(State)-Long Island.

UNITED STATES (continued)

Matthews, William B Jr.
 The Macmillan marine atlas: New Jersey and Delaware waters including the Atlantic Intracoastal Waterway. 1968/69 [i.e. 1st] ed. [New York, Macmillan Co., 1968]
 56 p. (chiefly col. maps) 36 cm. (Macmillan marine atlas series)

1. Nautical charts - New Jersey. 2. Nautical charts - Delaware.

 Princeton University. Library.
 New Jersey road maps of the 18th century. Princeton, N.J., 1970 [c1964]
 [48] p. (chiefly maps) 26 cm.
 "Second printing, with corrections."

1. New Jersey - Road maps - To 1800. 2. Maps, Early - Facsimiles.

 Clay, James W.
 Metrolina atlas. Edited by James W. Clay and Douglas M. Orr, Jr. Chief cartographic assistant, Jefferson L. Simpson. Chapel Hill, University of North Carolina Press [1972]
 xi, 235 p. illus. (some col.), col. maps. 29 cm. \$13.95
 Includes bibliographies.

1. North Carolina - Economic conditions - Case studies. 2. South Carolina - Economic conditions - Case studies.

 Florin, John William
 Changing population of the Southeast [by] John W. Florin and Richard J. Kopec. Chapel Hill, University of North Carolina, Dept. of Geography [1973]
 [v], 67 (i.e. 71) p., 40 maps. 32x41 cm. (North Carolina. University. Dept. of Geography. Studies in geography, no. 5)
 Text for most maps printed on verso of preceding map.

1. Southeastern United States - Population - Maps.

UNITED STATES (continued)

Cowen, David J

Atlas of agriculture, South Carolina, 1960-1970, by David J. Cowen and Paul E. Lovingood. [Clemson, Dept. of Agricultural Economics and Rural Sociology, Clemson University, 1972]

64 p. maps. 28 cm. (South Carolina. Agricultural Experiment Station, Clemson. Dept. of Agricultural Economics and Rural Sociology. AE 350)

1. Agriculture - Economic aspects - South Carolina - Maps.

Arbingast, Stanley Alan, 1910-

Atlas of Texas [by] Stanley A. Arbingast [and others. Rev. ed.] Austin, University of Texas, Bureau of Business Research, 1973.

[vii], 132 p. chiefly maps (part col.) 28 x 36 cm.

1. Texas - Econ. condit. - Maps.

Fisher, William L

Environmental geologic atlas of the Texas coastal zone: Galveston-Houston area. By W.L. Fisher [and others]; cartography by J.W. Macon [and others] Pref. by Peter T. Flawn. Austin, Bureau of Economic Geology, the University of Texas at Austin, 1972.

[v], 91 p. illus., maps (9 fold. col. maps in pockets) 29 cm.

L.F. Brown, jr., project coordinator. Includes bibliography.

Contents.- Environmental geology, physical properties, environments and biologic assemblages, current land use

1. Natural resources - Galveston-Houston area, Texas - Maps. 2. Geology Texas - Galveston-Houston area - Maps.

Illinois. Division of Waterways.

Map atlas of Upper Illinois River.

[Rev. ed. Springfield, 1971]

[iii] p., 208 (i.e. 214) l. of maps (chiefly col.) 29x44 cm.

"Prepared from aerial and ground surveys made in the winter of 1964 and spring of 1965 for the Illinois Div. of Waterways by a mapping contractor. Some culture (highways, riverside industries, navigation aids, etc.) was revised in 1970."

1. Illinois River - Maps.

Borchert, John Robert, 1918-

Atlas of Minnesota resources and settlement. Prepared for the Minnesota State Planning Agency, by John R. Borchert and Donald P. Yaeger. Cartography directed by Patricia Burwell. Principal cartographer: Sandra Haas. Rev. ed. [Minneapolis] Dept. of Geography, University of Minnesota, 1969.

xiii, 262 p. maps (part col.) 22x27 cm. Two transparent overlays and generalized land use map of the Twin Cities metropolitan area (scale, ca. 1:130,000) in pocket.

1. Minnesota - Maps. 2. Minnesota - Economic conditions - Maps.

Socolofsky, Homer Edward, 1922-

Historical atlas of Kansas. By Homer E. Socolofsky and Huber Self. [1st ed.] Norman, University of Oklahoma Press [1972]

viii, 141, ix-xxxii p. 70 p. of maps. 31 cm. Text for each map printed on verso of following map.

Bibliography: p. ix-xvi. \$5.95

1. Kansas - Historical geography - Maps.

Idaho. University. Dept. of Geography.

Idaho economic atlas. Editor: Harry H. Caldwell. Moscow, Idaho, Idaho Bureau of Mines and Geology [1970]

82 p. illus., maps (some col.) 28 cm.

1. Idaho - Economic conditions - Maps.

Loy, William G

A preliminary atlas of Oregon [by] William G. Loy. [Eugene] Geography Dept., University of Oregon, 1972.

1 v. (various pagings) chiefly maps (1 map in pocket) 22x29 cm. Includes bibliography.

1. Oregon - Maps.

Smith, Stephen V

Atlas of Kaneohe Bay; a reef ecosystem under stress. By Stephen V. Smith, Keith E. Chave [and] Dennis T. O. Kam, in collaboration with Gerald S. Key [and others. Honolulu, University of Hawaii] 1973.

vii, 128 p. illus., maps. 29 cm.

....

LATIN AMERICA

Robinson, Margaret King, 1906-

Atlas of monthly mean sea surface and sub-surface temperatures in the Gulf of California, Mexico. [San Diego], Scripps Institution of Oceanography, [University of California] 1973.

19 p., 78 p. of maps. (San Diego Society of Natural History. Memoirs, 5) Includes bibliography.

1. Ocean temperature - California, Gulf of.

Robinson, Margaret King, 1906-

Atlas of monthly mean sea surface and sub-surface temperature and depth of the top of the thermocline: Gulf of Mexico and Caribbean Sea. San Diego, Scripps Institution of Oceanography, University of California, 1973.

[iv], 12 p., 93 p. of maps. (SIO Reference 73-8)

1. Ocean temperature - Mexico, Gulf of. 2. Ocean temperature - Caribbean Sea.

Inostroza Villagra, Héctor Manuel

Atlas oceanográfico de Chile; secciones horizontales de temperatura, salinidad, contenido de oxígeno y foefato preparado con datos obtenidos entre 1876 y 1968. [Por] H. Inostroza V. [Valparaiso?] Chile, Instituto Hidrográfico de la Armada, 1972.

21 p., 76 maps (chiefly col.) 45 cm. (Instituto Hidrográfico de la Armada. Publicación 3041)

1. Oceanography - Chile.

Editorial Kapelusz.

Coloratlas regional Argentina: físico, político, económico. [1. ed. Buenos Aires, 1973]

[iv, 68 (67 p. of col. maps)] p. 32 cm. Scale varies.

Maps numbered 53 through 89.

1. Argentine Republic - Maps.

Río, Manuel E

Geografía de la provincia de Córdoba, por Manuel E. Río y Luis Achaval ... Publicacion oficial. Buenos Aires, Compañia sud-americana de billetes de banco, 1904-05.

2 v. 28 cm. and atlas (8 fold. col. maps, 7 plates (some fold.)) 60x46 cm.

"Fuentes y bibliografía": v. 1, p. [xxiii]-xxix; v. 2, [p. [v]-vi.

Atlas in portfolio.

1. Córdoba, Argentine Republic (Province) - Description and travel.

2. Córdoba, Argentine Republic (Province) - maps.

Brazil. Diretoria de Hidrografia e Navegação.

Cartas de correntes de maré: pôrto de Madre de Deus. 1. ed. [Rio de Janeiro?] 1963.

[21] p. (chiefly col. maps) 23x30 cm.

1. Tides - Brazil - Madre de Deus - Charts, diagrams, etc.

EUROPE

Blaeu, Willem Janszoon, 1571-1638.

The sea-beacon. Amsterdam, 1643. With an introd. by C. Koeman. Amsterdam, Theatrum Orbis Terrarum, 1973.

[xv], 28, 162, 162 p. illus., maps. 43 cm. (Theatrum orbis terrarum; series of atlases in facsimile, 6th ser., v. 3)

Facsim. of the copy in the Bibliotheek van de vereeniging ter Bevordering van de Belangen des Boekhandels, Amsterdam.

1. Nautical charts - Europe - To 1800.

Gilbert, Martin, 1936-

British history atlas. Cartography by Arthur Banks. [1st American ed.] New York, Macmillan Co. [1971, c1968] 118 p. maps. 24 cm.

"First American edition 1969"

1. Gt. Brit. - Historical geography - Maps.

24 EUROPE (continued)

Kinnear, Michael.

The British voter; an atlas and survey since 1885. Cartography by the author. Ithaca, N.Y., Cornell University Press [1968]

158 p. maps. 31 cm.

Includes bibliography.

1. Elections - Gt. Brit. 2. Gt. Brit. - Pol. & Govt. - 1837-1901.

[Also have British ed. (Batsford).]

France. Direction de la météorologie nationale.

Atlas climatique de la France, préparé et publié sous la direction de Jean Bessemoulin. Paris, 1969.

1 v. (unpaged) 45 plates (incl. 246 col. maps) 53 cm.

Illus. on versos of some plates.

Includes bibliographical references.

Issued in loose-leaf binder.

1. France - Climate - Maps.

Bollmann, Hermann, 1911-

Staedte. Braunschweig, Bollmann-Bildkarten-Verlag [1969?]

v. maps (part col.) 39 cm.

On cover: Bollmann-Bildkarte.

1. Cities and towns - Germany - Views.
2. Cities and towns - Europe - Views.
3. New York (City) - Description - Views.

[Library has V.1-2. To be complete in 3.]

Liedtke, Herbert

Topographischer Atlas Rheinland-Pfalz [von] Herbert Liedtke, Gerhard Scharf [und] Walter Sperling. Hrsg. vom Landesvermessungsamt Rheinland-Pfalz. Neumunster, K. Wachholtz, 1973.

216 p. illus., col. maps, (1 fold. col. in pocket) 34 cm.

Bibliography: p. 193-213.

1. Rhineland-Palatinate-Maps, Topographic.

Pamías Ruiz, José, firm.

Gufa urbana de Barcelona; orba especialmente útil a los funcionarios públicos, turistas, conductores de vehículos; comercio en general. 2. ed. Barcelona, 1965.

256 p., 161 p. of col. maps. 15 cm.

1. Barcelona - Maps.

Magini, Giovanni Antonio, 1555-1617.

Italia. Bologna, 1620. With an introd. by Roberto Almagia. Edited by Mrs. Fiorenza Maranelli. Amsterdam, Theatrum Orbis Terrarum, 1974.

xxix, [viii], 24 p. 61 fold. maps. 43 cm. (Theatrum Orbis Terrarum; series of atlases in facsimile, 6th ser., v.5)

Introd. in English and Italian.

1. Italy - Maps - to 1800.

Greece. Ethnike Statistike Hyperesia.

Biomechanikos atlas tes Hellados.

Industrial atlas of Greece, census of 1963. Athens, 1966. [pref. 1967]

[2] l., [46] l. of col. maps. 45 x 60 cm.

(title transliterated)

1. Greece, Modern - Indus. - Maps.
2. Greece, Modern - Econ. condit. - 1918-

Kayser, Bernard

Oikonomikos kai koinonikos atlas tes Hellados. Economic and social atlas of Greece [by Bernard Kayser and Kenneth Thompson in collaboration with Roger Vaternelle, Basil Coukis, and a group of employees of the National Statistical Service of Greece] Atlas économique et social de Grèce. Athens, 1964.

1 v. (unpaged) illus., maps (part col.) 44 x 48 cm.

1. Greece, Modern - Econ. condit. - 1918- Maps. ...

Kish, George, 1914-

Economic atlas of the Soviet Union. With the assistance of Ian M. Matley, Holly Fry, and Betty Bellaire. 2d. ed., rev. Ann Arbor, University of Michigan Press [1971]

90 p. col. maps. 27 cm. \$12.50
Bibliography: p. 82-83.

1. Russia - Economic conditions - Maps.

ASIA

Rand McNally illustrated atlas of China. [Chicago] Rand McNally, 1972.

80 p. illus.(some col.),col.maps.
24x39 cm.

"From materials prepared by the United States Government."

1. China (People's Republic of China, 1949-) - Maps.

Chen, Cheng-siang

Atlas of land utilization in Taiwan, by Cheng-siang Chen. [Taipeh] National Taiwan University, 1950.

8 p., 121 p. of maps, [32] p. illus., tables. 38 cm.

Title and letterpress in Chinese and English. Scale of principal maps ca. 1:1,400,000. To accompany the author's "Land utilization in Taiwan," issued in Chinese and English language editions.

1. Land - Formosa - Maps. 2. Formosa-Maps.

Barton, Thomas Frank, 1905-

Southeast Asia in maps [by] Thomas F. Barton, Robert C. Kingsbury [and] Gerald R. Showalter. [Chicago] Denoyer-Geppert [1973,c1970]

96 p. illus.,maps. 28 cm.

1. Asia, Southeastern - Maps.

AFRICA

The atlas of Africa. [Prepared and published by "Jeune Afrique" under the direction of Régine van Chi-Bonnardel. 1st American ed.] New York, The Free Press; [Paris] Editions Jeune Afrique [1973]

335 p. col.maps. 41 cm.

Also published in French. Titles on spine: Atlas Jeune Afrique, the African continent.

1. Africa - maps. I. Nguyen van Chi-Bonnardel, Régine, 1926-

AFRICA (continued)

Tanzania in maps: graphic perspectives of a developing country; edited by L. Berry. New York, Africana Pub. Corp. [1972,c1971]

172 p. maps. 29 cm. Bibliography: p. 146-152.

1. Tanzania - Maps. 2. Tanzania - Description and travel. I. Berry, Leonard, 1930- ed.

Centre Scientifique et Médical de l'Université Libre de Bruxelles en Afrique Centrale.

Madagascar. Cartes de densité et de localisation de la population. Etablies par le CEMUBAC sous la direction de Pierre Gourou. Bruxelles, Centre scientifique et médical de l'Université libre de Bruxelles en Afrique Centrale, CEMUBAC; Paris, Office de la recherche scientifique et technique Outre-Mer, ORSTOM, 1967.

28 p., 3 fold. col. maps. tables. 37 cm. bfr 540.-

Issued in portfolio.

1. Madagascar - Population - Maps. I. Gourou, Pierre, 1900-

Zambia in maps: graphic perspectives of a developing country, edited by D. Hywel Davies. New York, Africana Pub. Corp. [1972,c1971]

128 p. illus., maps. 29 cm. Bibliography: p. 123-125.

1. Zambia - Maps. I. Davies, D. Hywel, ed.

Bultot, Franz, 1924-

Atlas climatique du bassin congolais. [Bruxelles] I.N.E.A.C., 1971-

v. illus.,col.maps. 33 cm. (Institut national pour l'étude agronomique du Congo. Publications)

Includes bibliography.

1. Congo River watershed - Climate - Maps.

[Map Library has only 3v. Publisher indicates 4th and last volume will probably be published in 1975.]

AFRICA (Continued)

Smet, Roger E de
 Cartes de la densité et de la localisation de la population de la province du Katanga (République du Zaïre) [Bruxelles] 1971.

38 p. illus., 3 fold. col. maps. 37 cm.

At head of title: Centre Scientifique et Médical de l'Université Libre de Bruxelles en Afrique Centrale.

Title from portfolio in which issued.

Scale of maps: 1:1,000,000.

"Province du Katanga: liste alphabétique des territoires, circonscriptions, groupements ou groupes": fold. leaf inserted. Includes bibliography.

1. Katanga, Zaïre (Province) - Population - Maps.

 Clarke, John Irms, Ed.

Sierra Leone in Maps: Graphic perspectives of a developing country. Africana Press, [1972, c1969] 2d ed.

1. Sierra Leone - Maps. 2. Sierra Leone - Description and travel.

Liberia in maps: graphic perspectives of a developing country. Edited by Stefan von Gnielinski. New York, Africana Pub. Corp., [1972]

111 p. illus., maps. 29 cm.

Includes bibliography.

1. Liberia - Maps.

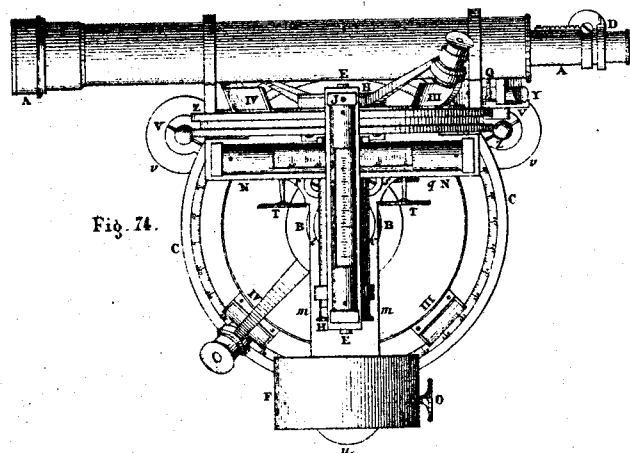

Fig. 74.

PACIFIC OCEAN

Barkley, Richard A 1929-
 Oceanographic atlas of the Pacific Ocean. Honolulu, University of Hawaii Press, 1968.

20 p., 156 p. of illus., maps. 32x46 cm.

Bibliography: p.13-20.

1. Oceanography - Pacific Ocean - Charts, diagrams, etc.

 California. University, San Diego. Scripps Institution of Oceanography, La Jolla.

Bathymetric atlas of the north-central Pacific Ocean. Washington, U.S. Naval Oceanographic Office, 1971.

1, 1a-b, 2 p. 75 p. of maps. 21x28 cm. (H.O. pub. no 1302-S)

Scale of maps ca. 1:4,000,000.

Includes bibliography.

1. North Pacific Ocean - Bathymetric maps.

 [Editor's Note: The format of these entries does not necessarily conform to that used at UCLA; the data herein presented is designed to present the essential information regarding the atlas cataloged. Due to technical limitations, certain portions of the cataloging record as provided by Anna Blustein have been omitted. The Editor will accept responsibility for errors in proper cataloging presentation.]

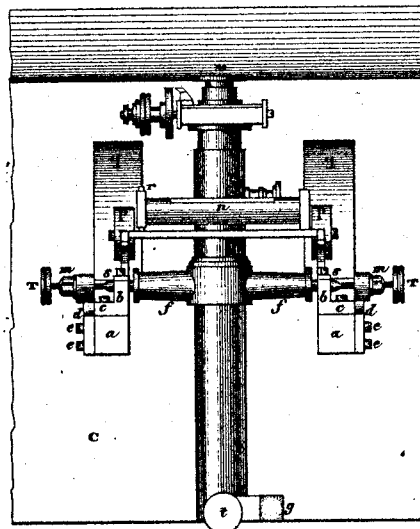

ABBREVIATIONS AND ACRONYMS IN THE MAPPING SCIENCES: A FIRST LISTING

by

Harry J. Steward*
Assistant Professor
Department of Geodetic Science
Ohio State University

The shortening of titles and explanations by the use of abbreviations, acronyms, mnemonics, and the like is a long established practice in the search for brevity in written and spoken communication. A minor hallmark of the so-called 'information explosion' is the ever growing proliferation of such terms. Technological advance, literature expansion, and the growth and change of organizational activities are its chief progenitors.

The mapping sciences (geodesy, surveying, cartography, photogrammetry, photointerpretation, remote sensing) cover a comparatively restricted area compared with some other sciences but nevertheless, the number of such terms relevant to the scope of its activities grows lengthier each year. There is clearly a need for some interested person to compile and collate a definitive list for reference purposes.

What follows is offered as raw input to such a hypothetical complete listing. Its compilation was governed by purely pragmatic reasons. In 1972, the Geodetic Science Department of the Ohio State University, changed its campus location and its library moved from the Geology collection to the more convenient Mathematics one. The Mathematics Librarian was unused to mapping literature and in order to help her handle literature queries from students, organize ordering, cataloguing etc., she requested help in deciphering the many unfamiliar abbreviations being encountered.

The result is given below. It is very clearly ad hoc and makes no pretense at complete coverage. Its content stems, as implied above, from journal abbreviations, technological terms and organizational titles. No extensive remarks are necessary on its format or coverage. It should however, be noted that some of the individual citations vary somewhat in the literature; i.e., a different disposition of capitals and lower case letters sometimes occurs. Those recorded here are the most commonly encountered. Some of the material is ephemeral or records defunct organizations, systems, etc.; but, of course, this remains valuable for retrospective searches. Few acronyms in the sense of coherent word forms occur but, none the less, many others of less sublime pronunciation are commonly used as such in verbal discussions.

[* Dr. Steward is Review Editor of both *Surveying and Mapping*, and the new semi-annual journal *The American Cartographer*.]

ACD	-Automatic Contour Digitizer
ACI	-Association Cartographique Internationale (see also IKV and ICA)
ACIC	-Aeronautical Chart and Information Center; St. Louis Mo., (see also DMAAC)
ACML	-Association of Canadian Map Libraries
ACSM	-American Congress on Surveying and Mapping: N.B. "on" <u>not</u> "of"
ADV	-Arbeitsgemeinschaft der Vermessungsverwaltungen
AGI	-Association Géodésique Internationale (see also I.A.G.)
AIC	-Associazione Italiana di Cartografia

AIC	-Annuaire International de Cartographie (see also IVC and IJC)
AMS	-Army Map Service (see also USATOPOCOM and DMATC)
APC	-Aircraft Position Charts
API	-Air Photo Interpretation
APT	-Automatic Picture Transmission Vidicon
AR	-Army Regulations; U.S. Army
ARDA	-Agricultural Rural and Development Organisation; Canada
ASC	-Aerospace Planning Charts
ASCE	-American Society of Civil Engineers
ASP	-American Society of Photogrammetry
AULT	-Automatic Location and Identification
AVCS	-Advanced Vidicon Camera System
AVN	-Allgemeine Vermessungs Nachrichten; journal, Karlsruhe, W. Germany
BCFC	-Bulletin du Comité Francais Cartographie; journal, Paris
BCS	-British Cartographic Society
BGI	-Bibliographic Géodésique Internationale (see also IGB)
BIT	-Nordisk Tidsskrift for Information - Behandling; journal, Norway
BM	-Bench Mark
BTB	-Bund der Technischen Beamten
BUL	-Bildmessung und Luftbildwesen; journal, Karlsruhe, W. Germany
CAD	-Chart Analysis Device
CATS	-Chicago Area Transportation Study
CCRS	-Canada Centre for Remote Sensing; Ottawa
CEC	-Continental Entry Chart
CFC	-Comité Francais Cartographie
CGIS	-Canadian Geographic Information System: geographic information system
CGS	-Coast and Geodetic Survey (see also USCGS),
CHUM	-Chart Updating Manual
CHS	-Canadian Hydrographic System
CNIIGAİK	-Central'noqo Naučno-Issledovatel' skogo Instituta Geodezii, Aerofotos-emki i Kartografii; U.S.S.R.
CNRS	-Centre National de la Recherche Scientifique; Paris, France
COGO	-Co-ordinate Geometry; computer acronym
COLMAP	-Colour Map; computer acronym, Great Britain
CRT	-Cathode Ray Tube
DCS	-Data Correction System (ERTS)
DIA	-Defense Intelligence
DIME	-Dual Independent Mapping and Encoding System; geographic information system
DIN	-Deutsche Industrie Norm (en) (German Industrial Standards)
DGfK	-Deutsche Gesellschaft für Kartographie
DGR	-Digital Graphic Recorder
DMA	-Defense Mapping Agency
DMAAC	-Defense Mapping Agency Aerospace Center; St. Louis, Mo. (formerly ACIC q.v.)
DMAHC	-Defense Mapping Agency Hydrographic Center; Washington, D.C.
DMATC	-Defense Mapping Agency Topographic Command; Washington, D.C. (formerly USATOPOCOM and AMS q.v.)
DMS	-Department of Military Survey; Great Britain
DoDMC and G	-Department of Defense Mapping, Charting and Geodetic (Operations)
DOS	-Department of Overseas Surveys; Great Britain
DRID	-Direct Readout Image Dissector
DRIR	-Direct Readout Infrared

DVWG	-Deutschen Verkehrswissenschaftlichen Gesellschaft
ECU	-Experimental Cartography Unit; Royal College of Art, Great Brit.
EDP	-Electronic Data Processing
EIRA	-Ente Italiano Rilievi Aerofotogrammetrie
EM	-Electromagnetic
ERDL	-Engineering Research and Development Laboratories
ERIM	-Environmental Research Institute of Michigan (Ann Arbor, Mich.)
EROS	-Earth Resources Observation Satellite
ERTS	-Earth Resources Technology Satellite
ESSA	-Environmental Science Services Administration
ESSELTE	-Sveriges Litografiska Tryckerier; Stockholm, Sweden
ETHZ	-Eidgenössische Technische Hochschule Zürich
ETL	-Engineering Topographic Laboratories; Fort Belvoir, Va.
FAA	-Federal Aviation Authority
FIG	-Fédération Internationale des Géomètres
FLIPS	-Flight Information Publications
FM	-Field Manual; U.S. Army
FOGRA	-Förschung im graphischen Gewerbe
FPR	-Flat Plate Radiometer (non-imaging)
FWS	-Filter Wedge Spectrometer
GEOREF	-Geographic Reference System
GIMRADA	-Geodesy, Intelligence and Mapping, Research and Development Agency
GKK	-Generalkatalog des Kartographischen Schrifttums
GNC	-Global Navigation and Manning Chart
GT	-USAF Gnomonic Tracking Chart
HD	-Hydrographic Department; Great Britain
HMSO	-Her Majesty's Stationery Office; Great Britain
HRIR	-High Resolution Infrared Scanners (Imaging)
IAG	-International Association of Geodesy (see also AGI)
IAGS	-Inter-American Geodetic Survey
ICA	-International Cartographic Association (see also ACI and IKV)
ICAO	-International Civil Aviation Organization
IDCS	-Image Dissection Camera System
IFR	-Instrument Flight Rules
IGB	-International Geodetic Bibliography (see also BGI)
IGS	-Instituto Geográfico y Catastral; Madrid, Spain
IGN	-Institut Géographique National; Paris, France
IGU	-International Geographical Union (see also UGI)
IHB	-International Hydrographic Bureau
IJC	-Internationales Jahrbuch für Kartographie (see also AIC and IYC)
IKV	-Internationalen Kartographischen Vereinigung (see also ICA and ACI)
ILS	-Instrument Landing Systems
IMW	-International Map of the World; United Nations
IRIA	-Infra-red Information and Analysis (Ann Arbor)
IRIS	-Infrared Interferometer Spectrometer (non-imaging)
IRS	-Infrared Spectrometer (non-imaging)
ITC	-International Institute for Aerial Survey and Earth Sciences; Enschede, Netherlands
IYC	-International Yearbook of Cartography (see also AIC and IJC)
JGR	-Journal of Geophysical Research
JN	-USAF Jet Navigation Chart; N.B. this is not the same as JNC
JNC	-Jet Navigation Chart; N.B. this is not the same as JN
KN	-Kartographische Nachrichten; journal, Bad Godesberg, W. Germany
KNAG	-Koninklijk Nederlands Aardrijkskundig Genootschap
LCC	-Loran C. Navigation Chart

LINMAP	-Line Printer Mapping; computer acronym, Great Britain
L/MF	-Low/Medium Frequency
LRIR	-Low-Resolution Infrared Radiometer (non-imaging)
MAV	-Medium-Angle Vidicon
MICMAC	-Michigan Inter-University Community of Mathematical Geographers
MIIGAik	-Moskovskogo Instituta Inzenerov Geodezii Aerofotos-emki i Kartografii; Moscow, U.S.S.R.
Mittlbl. BDVI	-Mitteilungsblatt des Bundes der Öffentlich Bestellen Vermessungsingieure
Mittlbl. der DVW	-Mitteilungs blatt der Deutschen Vereins für Vermessungswesen
Mittlbl. des DVW Bayern	-Mitteilungsblatt des Deutschen Vereins für Vermessungswesen, Landesverein Bayern
Mittlbl. des DVW Hessen	-Mitteilungsblatt des Deutschen Vereins für Vermessungswesen, Landesverein, Hessen
Mittlbl. des DVW Nordwest	-Mitteilungsblatt für die Mitglieder des Deutschen Vereins für Vermessungswesen
Mittlbl. des DVW Rheinland-Pfalz	-Mitteilungsblatt des Deutschen Vereins für Vermessungswesen Landesverein Rheinland-Pfalz
MRIR	-Medium-resolution infrared scanners (imaging)
MSC	-Multispectral camera
MSCC	-Multicolor spin-scan cloud camera
MSL	-Mean Sea Level
MSS	-Multi-Spectral Scanner
MUSE	-Monitor of Ultraviolet Solar Energy
MVR	-Microwave Radiometer (non-imaging)
NADUC	-Nimbus/ATS Data Utilization Center, NASA Goddard Space-flight Center, Greenbelt, Md.
NaKaVerm	-Nachrichten aus dem Karten-und Vermessungswesen
NARIS	-Natural Resources Information System; geographic information system University of Illinois
NAV	-Narrow-Angle Vidicon
NAVOCEANO	-Naval Oceanographic Office; Washington, D.C.
NCC	-National Climatic Center, Asheville, N.C.
NDB	-Radio Beacons on Compass locations
NDPF	-NASA Data Processing Facility, Goddard Spaceflight Center, Greenbelt, Md.
NERC	-Natural Environmental Research Council (Britain)
NESS	-National Environmental Satellite Service, Suitland, Md.
NIIGAik	-Novosibirskogo Instituta Inzenerov Geodezii, Aerofotosemki i Kartografii (U.S.S.R.)
NM	-Nautical Mile
NOAA	-National Oceanographic and Atmospheric Administration; Washington, D.C.
NOS	-National Ocean Survey; Washington, D.C.
NRC	-National Research Council; Washington, D.C.
NSSDC	-National Space Science Data Center, NASA Goddard Spaceflight Center, Greenbelt, Md.
NTB	-Neue Technische Bücher
OCs	-Airport Obstruction Charts
OEEPE	-Organisation Européenne d'Estudes Photogrammétriques Expérimentales
ONC	-Operational Navigational Charts

ONR -Office of Naval Research; Washington, D.C.
 ORSTOM -Office de la Recherche Scientifique et Technique Outre-mer
 OS -Ordnance Survey; Great Britain
 OZF -Österreichische Zeitschrift für Vermessungswesen; journal,
 Vienna, Austria
 PE -Photogrammetric Engineering; journal, Falls Church, VA.
 PRATSS -Pennsylvania Research Associates Terrain Scanning System
 PVA -Polyvinyl Alcohol Process
 RACOMS -Rapid Combat Mapping System
 RADC -Rome Air Development Center; Rome, New York State
 RBV -Return Beam Vidicon
 RCA -Royal College of Art; London, Great Britain
 RICS -Royal Institute of Chartered Surveyors; Great Britain
 RNG -(L/MF) Ranges
 SAR -Synthetic Aperture Radar
 SCI -System Corrected
 SCMR -Surface Composition Mapping Radiometer (imaging)
 SCR -Selective Chopper Radiometer
 SfV -Schweizerische Zeitschrift für Vermessung, Kulturtechnik;
 journal, Winterthur, Switzerland
 SHOM -Service Hydrographique et Océanographique de la Marine
 SIDS -Standard Instrument Departure Charts
 SIFET -Societa Italiana di Fotogrammetria e Topografia
 SIRS -Satellite Infrared Spectrometer (non-imaging)
 SLAGMDB -Special Libraries Association, Geography and Map Division,
 Bulletin; journal, New York City
 SLAR -Side Looking Airborne Radar
 SLR -Side Looking Radar
 SMVR -Scanning Microwave Radiometer (imaging)
 SNTL -Štatni nakladeselství technické literatury (Czechoslovakia)
 SOD -Superintendent of Documents, U.S. Government Printing Office,
 Washington, D.C.
 SPIE -Society of Photographic Instrumentation Engineers
 SR -Scanning Radiometer (imaging)
 SSCC -Spin-Scan Cloud Camera
 SYMAP -Synagraphic Mapping (Computer system acronym)
 TAC -Technology Application Center, University of New Mexico,
 Albuquerque, N.M.
 TAGA -Technical Association of the Graphic Arts
 THIR -Temperature-Humidity Infrared Radiometer (imaging)
 TM -Technical Manual; U.S. Army
 TOPOCOM -Topographic Command (see also AMS and DMATC)
 TPC -Tactical Pilotage Charts; U.S.A.F.
 TTS -True to Scale
 UGI -Union Géographique Internationale (see also IGV)
 UNAMACE -Universal Automatic Map Compilation Equipment
 USAES -U.S. Army Engineer School
 USATOPOCOM -U.S. Army Topographic Command (formerly AMS, later DMATC q.v.)
 USCGS -United States Coast and Geodetic Survey; Washington, D.C.
 USGS -United States Geological Survey; Reston, VA.
 USNOO -U.S. Naval Oceanographic Office; Washington, D.C.
 UTM -Universal Transverse Mercator

VHF	-Very High Frequency
VL 30/VLC 30	-Air Surface Loran Navigation Charts (VL30 used in conjunction with Loran A: VLC30 used in conjunction with Loran C)
VLBI	-Very Long Base Interferometry
VR	-Vermessungstechnische Rundschau; journal, Bonn, West Germany (now reformed as Vermessungswesen und Raumordnung)
V/R	-Omni directional Ranges
WAC	-World Aeronautical Chart
WAML	-Western Association of Map Libraries
WAV	-Wide-Angle Vidicon
WFR	-Wide-Field Radiometer (non-imaging)
WGS	-World Geodetic System
WRIS	-Wildland Resource Information System: geographic information system U.S. Forest Service
ZD	-USAF/USN Equidistant Chart
ZFV	-Zeitschrift für Vermessungswesen; journal, Hanover, West Germany
ZIID	-Zentralinstitut für Information und Dokumentation
ZIV	-Zentralen Informatimstell für Verkehr
ZLID	-Zentrale Letistelle für Information und Dokumentation des Vermessungs und Kartenwesens

MAP CATALOGERS BEWARE!

U.S. Library of Congress to Revise CLASS G

Mary Larsgaard and Stanley Stevens, during the WAML Fall Meeting, 1974 in San Francisco, reported on their observations of the Special Libraries Association annual meeting held in June at Toronto.

The most important news was the announcement by representatives of the Library of Congress that the Classification Class G (which includes Atlases and Maps schedules) has been revised, and the revised schedule will be published in 1975.

The major areas of changes are: 1. editing for present LC editorial policies with reference to alternate spellings, abbreviations, etc. 2. modernizing geographic spellings and terminology. 3. adding new states, countries, etc. 4. revising geographic/political entities to reflect current usage, i.e., Germany (divided), Ireland (divided), Korea (divided), Vietnam (ignored). 5. expanding the schedule within countries, island groups, etc. where necessary, using whole numbers, decimals, and the colon (which takes place of the expanded cutter). The decimal has thus far been used mainly in the atlas schedule. 6. eliminating unused and/or ambiguous numbers. 7. introduction of new devices and aids to facilitate the classification process such as the previously mentioned colon, decimals, triple cutters, and maps inserted in the schedule to clarify precisely what is included under large geographic region captions.

This announcement led the two observers to offer the following advice:
"...don't make any major cataloging decisions until the new schedule is published, and don't fail to order a copy of the revised schedule."

Geography and Map Division Meetings
 Special Libraries Association Annual Meeting
 Four Seasons-Sheraton, Toronto, Ontario, Canada. June 9-13, 1974

by

Mary Larsgaard
 Map Librarian, Central Washington State College
 Ellensburg, Washington 98926

Secure in my belief that all papers and commentary given at Geography and Map Division meetings would eventually appear in the G&M Division Bulletin or in Special Libraries, and that Stanley Stevens, who, since he was presenting a paper at one of the meetings, might be considered WAML's official representative and therefore would be giving a report on SLA to WAML members, I took absolutely no notes during the SLA G&M Division meetings. It therefore came as a considerable shock to me when I discovered that Stan and I jointly (the latter is the word that saved me) were to present a report on SLA to WAML; of course then I knew why I had felt vaguely uneasy and slightly guilty during the meetings, as I sat with hands empty that yearned to grip a pen. Enough of breast-beating and gnashing of teeth, and on to the action.

The conference actually (and perhaps fittingly) began with a conference-wide reception in the exhibits area on the evening of June 9; the exhibitors kindly donated two drinks per conferee, leading to the sort of party where I found myself directly behind a woman I had last seen in August of 1973 in Grenoble, France, at an International Federation of Library Associations meeting.

The June meeting of the Geography and Map Division was a full one: it came as no surprise to me to learn that the G&M Division is one of the more active divisions of SLA. Things started off at the sensible hour of 10 a.m. on Monday, June 10, with a business meeting, perhaps on the theory of getting the worst over-with first, although as business meetings go, this one was quick-paced, informative, and relatively painless.[1] Next was a singularly disastrous lunch of what the Four Seasons-Sheraton Hotel fondly believed to be *quiche Lorraine*, fortunately followed by a most delightful talk given by H. Roy Merrens, of the Geography Department of York University in Downsview, Ontario, concerning a map, "People's Guide to the Toronto Waterfront," he and a few friends put together, discussing how he ever got involved in the first place, and selling quite a few copies of the maps in the process. I have brought along a copy of the map for you to look at; the person unwise enough to attempt to steal it will be turned into a rubber duckie at my earliest possible convenience.* Mr. Merrens noted that the map contravenes standard cartographic practice in several ways-- gaudy colors and comic drawings (distantly related to the dragons on old maps) being two--but it is an enjoyable, informative map.

After a brief break, we went on to the next topic, which was historical cartography; Robert Karrow, Jr., gave a history of map collecting at the Newberry Library in his discussion of the Herman Dunlap Smith Center for the History of Cartography, noting current activities and future plans of the Center, such as lectural series. Ralph Ehrenberg of the National Archives was next with his discussion of "Nature and Value of Cartographic Records in Archives," a thesis that most map librarians, being completely unprejudiced, would consider self-evident. William Easton of Illinois State University at Normal, one of the deans of map librarianship in the United States, gave a brief history of Portolan charts; he plans to do more research on the Portolans, as he finds

* Delivered to the WAML Membership meeting, San Francisco, Oct. 25, 1974; unfortunately the Toronto map to which Ms. Larsgaard refers cannot be produced here.

them to be of continuing interest. The last in the discussions on Historical Cartography was Charles Taylor of the National Archives, discussing the feasibility of creating high quality microfilm copies of large, old, detailed maps; findings of a pilot study were that reduction ratios of 10x or less are required to insure excellence in reading and printing from the microfilm, and that 105mm microfilm is the most appropriate film size. At this point, there was a grateful adjournment for supper. Following supper was the SLA scholarship event: Norman Wisdom, English Comedian, at O'Keefe Center; I restrained myself from going without too much difficulty, which may have been fortunate, as I gathered from people who went that it was marginally acceptable if you liked English comedy, and completely deplorable if you didn't.

Tuesday, June 11, began with a panel on Cartographic journal publishing. John Wolter of the Library of Congress began the panel with an analysis of journal publication in cartography, giving a brief historical background of cartographic journals. WAML's Stanley Stevens was next, with, "Whose Journal is it? Members' or Editor's?", in which he gave a history of the WAML Information Bulletin; having become a member of WAML somewhat after its genesis, I found much of his information new, and the paper itself a seminal history of WAML. Lynn S. Mullins, the editor of the G&M Division Bulletin, was next, giving a brief history of the Bulletin and its problems. Julia Staniland, business manager for the Bulletin, put in a plea for SLA G&M Division members to send her their changes of address, not just to the SLA main office. Bernard Gutsell followed with "Editing The Canadian Cartographer," explaining the role grants play in financing a journal; since The Canadian Cartographer is not the organ of an organization, it must seek financing elsewhere. Judy Olson gave a brief discussion of the beginnings of The American Cartographer, a new publication of the American Congress on Surveying and Mapping.[2]

Tuesday afternoon was an enjoyable hodge-podge -- listed as "From Remote Sensing to Fantasy Maps", in the SLA program, due to last minute scheduling problems, it began with Mr. Hayward giving a most scholarly presentation replete with slides, on the Canadian equivalent of Sanborn maps;[3] the paper was a history of one company's fire insurance mapping in Canada. The next speaker was Michael O. Shannon, speaking on "Researcher's Dilemma: The New York City Master Plan," in which an aura of humorous, slightly hopeful despair was projected as Mr. Shannon discussed the growth and fate of New York City's present master plan. Ms. Margaret Ross next gave a combination travelogue-survey of some map collections in India, Australia, and New Zealand, which she visited on sabbatical leave from Wayne State University. Jeremiah Post of the Free Library of Philadelphia finished off the afternoon with "Cartographic Fantasy: or, How I Converted My Personal Hobby into an Academic Study," in which he discussed his book, the Atlas of Fantasy, and fantastic maps generally.

Wednesday, June 12th, the Geography and Map Division met jointly with the Association of Canadian Map Libraries at New College [University of Toronto], about a mile from the Seraton. I was not able to go to the joint meetings as I had an important government documents meeting to attend.

Thursday was a geographer's tour, covering the Toronto lakeshore, industrial land use between Toronto and Hamilton, and Hamilton. The morning began with the buses taking us to the McMaster University Map Library, where an excellent slide show plus cassette dialogue on using the map library (including one slide of a widely grinning little old lady librarian, complete with bun, wire-framed glasses, and a rose gripped firmly between her large, horse-like teeth, with a balloon above her head containing the word "Nyess?", and the cassette earnestly enjoining the listener-watcher to ask the friendly librarian for help.) The map library had an excellent display of nineteenth century maps

of the area. After a box lunch out on the lawn in front of the building containing the map library, it was once again to the buses, and then to Dundurn Castle (where it began to sprinkle) the home of one of Hamilton's first lawyers (the castle was restored for Canada's centennial); the tour included a working kitchen that handed out fresh, warm bread. After a brief stop, at a rock garden, we went driving around the rural area, observing housing types of late nineteenth century Canada. The tour was made worthwhile and enjoyable by the presence of a knowledgeable commentator-guide in the bus, which took dirt roads where no other bus had ever trod before. By 5:00 p.m., a horde of hungry map librarians were ready for the promised barbecue supper at the home of Kate Donkin, map librarian at McMaster University. Being a brave woman, and possessed of a like-minded husband, Mrs. Donkin had invited sixty-odd SLA members to her house for supper; it pleases me to report that the hamburgers, the Canadian sparkling rosé wine, the fresh relishes, and the company were all superb. I left a bit early because I had an early morning plane to catch; Stan will, I am sure, be pleased to enlighten you on all the lurid details of what happened after I left at about 8:00 p.m.

In summary, the G & M Division had an excellent convention, well-planned, diverse, and busy; Alberta Auringer Koerner deserves every member's thanks, not to mention a tall, cold glass of the beverage of her choice. Next year, SLA will be held at the Palmer House, Chicago, June 8-12, 1975. Plan ahead!

[1] For a report of the business meeting, see Richard Stephenson's report in the Library of Congress Information Bulletin 33(28): A-139-140, July 12, 1974.

[2] The Tuesday lunch speaker was M. Leonard Bryan, on "Remote Sensing Products of Use to Geography and Map Librarians."

[3] Robert Hayward, Public Archives of Canada, gave a paper on "Chas. E. Goad and Fire Insurance Cartography, 1874-1931."

WESTERN ASSOCIATION OF MAP LIBRARIES PROGRAM San Francisco, Oct. 24-25, 1974

- "Map Resources of San Francisco", by LaVonne Jacobsen, Calif. St. Univ.-SF
 "Map Symbols and Symbolization", by Edward Thatcher, University of Oregon
 "A Retail Map Store's Services", by Robert C. Jones, Rand McNally Map Store-SF
 "Automobile Club Mapping", by Harold Otness, Southern Oregon College-Ashland
 "Union Catalog of Maps", by Robert Rountree, Berkeley Documentation Center
 "The Sanborn Maps", by Gary Rees, Calif. St. Univ.-Northridge;
 Philip Hoehn, Bancroft Library, Univ. of Calif.-Berkeley
 Evelyn Woodruff, Calif. St. Univ.-San Jose
 "Map Librarians Beware; Library of Congress to Revise Schedule G; Observations on the Toronto SLA Conference", by Mary Larsgaard, Central Washington St. Col.
 Stanley Stevens, Univ. of Calif.-Santa Cruz
 "Map and Geographical Questions of a General Public", by Gil McNamee, BARC
 (Audrey Powers, BARC)
 "San Francisco Bay Region Study: an experiment in providing earth science information to the planning and decision-making community", by Virgil Frizzell, U.S. Geological Survey, Menlo Park
 "The Map Collection of the University of California at Davis, and recent significant acquisitions", by David Lundquist, Univ. of Calif.-Davis

ALMOST ALL YOU EVER WANTED TO KNOW ABOUT CANADIAN MAPS

or

AVAUNT, YE STRICTLY U. S. OUTLOOK!

The second meeting of the 1974/75 WAML year is scheduled for May 8-10, Thursday through Saturday, at the University of British Columbia. Frances Woodward, President of the Association of Canadian Map Libraries, and Gwen Gregor, presently in charge of the Map Division at the University Library [during the year-leave of Maureen Wilson], have graciously consented to be hostesses and program chairwomen for a joint WAML-western division of ACML meeting. The program will have as its theme Canadian maps and mapping, and will tentatively include talks on Canadian government mapping, provincial mapping, air surveying in B.C., Canadian hydrographic surveying, and urban history of Vancouver, and possible visits to the Vancouver City Archives (where repairing and restoration of maps is being carried on) and the library at Simon Fraser University (which has a computerized map cataloging system).

This is your opportunity to learn about Canadian maps in the best of all possible surroundings for that topic -- Canada. Vancouver is a beautiful, supremely enjoyable city, in many ways reminiscent of San Francisco and Seattle, as witness the large number of excellent restaurants.

Information concerning transportation, lodging, final tentative (not to be confused with early tentative) program, and weather information will be mailed approximately March 10, 1975. So save your pennies (and also larger denomination coins), sell your chief librarian up the river if need be, but plan on being in Vancouver next May, for some pleasure along with business!

Mary Larsgaard
WAML President-Elect
[program chairperson]

 CHRONOLOGY OF WAML MEETINGS*

			Host/Hostess
1966	Nov. 12**	Univ. of Calif. Berkeley	Sheila Dowd
1967	Jul. 1***	San Francisco State Univ.	Mimi Sayer
1967	Oct. 27	Calif. State Univ. Fresno	Elizabeth Landrum
1968	Mar. 16	U.S. Geological Survey-Menlo Park	Eleanore Wilkins
1968	Oct. 25	Scripps Inst. Oceanography-La Jolla	Barry Gardner-Smith
1969	Apr. 25	Univ. of Calif. Berkeley	Sheila Dowd
1969	Oct. 24	Univ. of Calif. Davis	Edward Jestes
1970	Apr. 25	Univ. of Calif. Santa Cruz	Stanley Stevens
1970	Oct. 30	Oakland Public Library	Gertrude Cordts
1971	Jun. 12****	Nut Tree Restaurant-Vacaville, CA.	Mimi Sayer
1971	Oct. 22-23	Univ. of Calif. Santa Barbara	Robert Sivers
(no Spring 1972 meeting)			
1972	Oct. 26-27	Calif. State Library-Sacramento	Mary Schell
1973	Mar. 29-30-31	Southern Oregon College-Ashland	Harold Otness
1973	Oct. 19-20	Univ. of Calif. Riverside	Gail Neddermeyer
1974	May 10-11	Calif. State Univ. Fresno	Herbert Fox
1974	Oct. 24-25	San Francisco Public Library	John Fetros

* Chronology does not include meetings of Committees; General Membership only.

** Exploratory Meeting

*** Founding Meeting; Constitution & By-laws adopted.

**** Joint Meeting with Geography & Map Division, Special Libraries Association.

U.S. FEDERAL MAP AND CHART DEPOSITORIES

by

Robert Sivers
Sciences-Engineering Library
University of California, Santa Barbara

Introduction

Mapping provides some of the most needed information in our nation's libraries. Today, information presented in map format is required not only by its classic users, including the military, the earth scientist and the transportation industry, but by a new breed of researcher interested in the multiple and interrelated environmental problems of population, pollution, energy, ecology, resource management and regional planning. The economy with which mapping displays complex environmental information, as well as the substantial funding of environmental research by governments and the private sector, provides a partial explanation for the great increase in the demand for this product. Whatever the full explanation may be, the shift of the demand curve for mapped information toward exponential increases raises the question of supply. And, for those libraries which must provide such information, the question of supply calls for a closer look at the role of map depositories in helping limited library budgets to meet such demand.

The federal government supports mapping, charting, geodesy and related activities well in excess of one-half billion dollars a year.[1] At this rate of expenditure, the current number of mapping products by federal agencies is large--indeed dominant--in terms of government produced mapping in the United States. In a general paper of this kind, it seems best, therefore, to concentrate on the major federal agencies which maintain mapping depositories. In so doing, we will be considering the depositories established by the Defense Mapping Agency, the National Ocean Survey and the United States Geological Survey. We will discuss: 1) some of the mapping products which they produce, 2) the conditions by which academic and non-governmental special libraries can qualify for these depositories, and, 3) the means by which non-depository libraries can provide potential users of mapping with detailed information about some of the major federal mapping products and the location of nearby depository libraries.

In order to discuss these topics, let us first establish some basic vocabulary necessary to describe some of the mapping produced by the three federal agencies under discussion.

Some Mapping Terminology

We can begin with the concept of scale. [2] Modern mapping usually expresses scale in the form of a ratio, for example, 1:250,000. Within typical production standards, it indicates the detail we can expect to see for the mapped area shown. The numeral "1", which begins a scale statement, indicates a unit of distance measurement chosen by the user for application to the map itself, e.g., one inch or one centimeter; the other numeral of the ratio, for example, "250,000", indicates the number of equivalent units of the actual surface mapped which one unit on the map represents. If the second numeral of the ratio

* Mr. Sivers, Assistant Head of the UCSB Sciences-Engineering Library, was the President of WAML 1969-70 and initiated the "Newsletter" - later to become the WAML Information Bulletin. This paper was delivered at the May 1974 Western Regional Federal Documents Workshop.

is large, say "1,000,000", the mapping is said to be small scale, and the data shown are often the larger physical features and generalized patterns of effects caused by human activities and decisions. If the second numeral of the scale is small, for example, "25,000", the scale is classified as large and the information graphed is detailed. If the scale ranges from around 1:100,000 up to 1:600,000, we can call it "medium scale" and expect moderate detail. The purpose of the mapping, the reliability of data, and the detail of available information are important determinants of the scale chosen.

The next bit of vocabulary concerns the distinction between maps and charts. Both provide information about an area using scale, symbols, location of labeled features, and a method of displaying a curved surface on a flat sheet called a projection. A chart, however, limits itself to data which is absolutely necessary for a special purpose operation, such as navigation by air and water.

The terms "topographic map" and "thematic map" are also important in describing the products of federal map depositories. Topographic maps show relief data at a measurable distance above or below a vertical reference line, usually mean sea level. Modern mapping usually displays this relief by contours, that is, lines tracing points of equal height or depth; or, by tinting for various height and depth intervals; or, by dots associated with numbers giving spot height or depth information. In addition, topographic maps show all data at a measurable distance, north or south, from the equator (latitude), and, east or west, from a reference line extending from the North Pole to the South Pole (longitude). The latter line usually passes through Greenwich, England. Many map librarians further define a topographic map as a multi-subject map usually displaying: 1) natural physical features, for example, rivers, lakes, mountains and valleys, 2) cultural data resulting from human activity, such as urban areas, cultivated areas, roads, land ownership or political borders, and, 3) areas of natural vegetation.

In contrast to the many subjects shown by a topographic map, a thematic map tends to emphasize one or two subjects. Familiar examples are soil maps, geologic maps, and bathymetric maps which emphasize water depths or submarine relief.

One more term and we shall be finished with our vocabulary exercise. An index map shows by means of named or numbered quadrangles overprinted on a simple outline or base map, the individual maps belonging to a series or set of maps. An index map is the key selection document for the map user and essential for map retrieval in a map library.

With this background, we can now turn to a consideration of the major federal depositories.

Defense Mapping Agency

Let us begin with the Defense Mapping Agency. Referred to as DMA, this organization was created in 1972. It consolidates under one command about 80% of the U.S. military mapping, charting and geodesy activities. It includes: 1) the former Army Topographic Command, which, in the DMA, is now called the Topographic Center; 2) the Hydrographic Center, incorporating most of the charting and mapping activities of the Naval Oceanographic Office, and, 3) the Aerospace Center which previously operated under the name, "Aeronautical Chart and Information Center." These components, and two others which will not be considered in this paper, make DMA one of the largest mapping organizations in the

world. In 1973, it employed some 9,000 individuals and was budgeted at about \$160 million a year.[3]

The DMA produces some mapping of the United States. However, its primary concern is the compilation and publication of small, medium and large scale topographic mapping, thematic mapping, nautical and aeronautical charting for world areas exclusive of the United States, its territorial waters, its dependencies and Puerto Rico. It produces about 160,000 items and distributes 90 million maps and charts annually.[4]

Since the interests of traditional users of mapping as well as environmental users of mapping do not and can not stop at United States borders, DMA products are of great interest to map librarians supplying research material.

The depository program of the DMA's Topographic Center has had the greatest impact on the kinds of libraries which are the subject of this paper. Let us consider this unit first.

Just after World War II, the DMA Topographic Center, then operating as the Army Map Service (AMS), established a program for distributing surplus military mapping. By 1950, 150 depositories had been established. By 1970, that number had grown to 195. During this time, over 26,000 different map sheets were distributed to each library.[5] This included large scale topographic mapping for portions of the United States, but by far the most important contributions were medium and small scale topographic maps for foreign areas.

The AMS depository program, later called the TOPOCOM depository program, can be credited for what we might call a renaissance in U.S. map libraries. First of all, it provided mapping to many libraries whose budgets precluded the purchase of comparable mapping, thereby stimulating the establishment and growth of map libraries. Second, it supplied topographic maps covering areas such as India and Western U.S.S.R. for which medium-scale topographic mapping has long been unavailable through normal civilian channels.

Unfortunately, this happy story ends on a sad note. Citing budgetary and other reasons, AMS stopped accepting additional depository members, during the sixties. From the civilian point of view, the timing of this policy could not have been worse. For, concurrently, our national and state governments were placing very high priority on the establishment or programmatic expansion of universities and colleges. These institutions, many of which had and continue to have research programs at least as important as those established in earlier times, can obtain a DMA Topographic Center depository only when an established member withdraws from the program, and the DMA gives permission for transfer of the depository to a library on an approved waiting list. The chances of obtaining a new depository were conservatively summarized by a TOPOCOM official in 1970: "To become a member of the ... program today one must be both patient and lucky." [6]

DMA Topographic Center issues a Map Depository Catalog containing index maps for the series it distributed. Librarians who wish to refer map users to DMA Topographic Center depository collections can consult the 2nd edition of Map Collections in the United States and Canada. A Directory, New York: Special Libraries Association, 1970, for listings of TOPOCOM depository members.

Let us now consider the other two DMA centers previously mentioned. The Aerospace Center operates no formal depository program. It does, however, provide fifty free aeronautical charts each year to selected academic libraries. The Center publishes three major unclassified series of small scale charts. Their cultural data is useful, particularly for Asia where, in general, mapping is difficult to obtain. They are up to date as well. The Operational Navigational Charts or ONC's are extremely valuable for general purpose, synoptic views of large areas, and are among the most handsome mapping available, particularly when obtained without aeronautical overprinting. Relief is shown by tinting, contouring, spot elevations and visually enhanced by a cartographic technique called "hill shading". The DMA Aerospace Center also provides a good, medium scale series, the Tactical Pilotage Charts. The Series, however, is far from complete.

The index maps for DMA Aerospace Center publications available to the general public can be obtained free from the National Ocean Survey, Distribution Division, (C-44), Riverdale, Maryland 20840. No listing of libraries holding these publications is easily available, but many medium and large size map libraries collect all series mentioned. Interested librarians can find medium and large size map libraries (as of 1969) identified on a special map in the map library directory previously mentioned.

The DMA Hydrographic Center produces about 5,000 nautical charts covering the world's oceans, their islands and coastlines, exclusive of the U.S., its possessions and Puerto Rico. These charts are of extraordinary value to oceanographers, geologists, environmentalists and other researchers. Ranging from large to small scales, they provide mapping of islands, harbours, ocean depths, and schematic plans of foreign port cities. Ocean floor relief is shown by a variety of cartographic techniques, predominantly spot depths. Although an occasional, ingenious map librarian has been able to obtain free supplies of these charts on a regular basis, no formal depository program exists. For example, Scripps Institution of Oceanography and UC Santa Barbara, both with strong programs in the marine sciences, have been forced to buy needed charting. Indexes for the charts are available for \$2.25 a set from DMA Hydrographic Center in Washington, D.C., 20390, or a western distribution center in Clearfield, Utah 84016.

Turning from the somewhat depressing situation for military mapping depositories to those under control of federal civilian agencies, the picture is more encouraging.

The National Ocean Survey

The National Ocean Survey, known as NOS, is a part of the National Oceanic and Atmospheric Administration. In fiscal year 1972, NOS was funded at over 41 million for its charting, mapping and geodetic activities.[7] NOS is the primary publisher of nautical charting for U.S. marine waters including its dependencies and Puerto Rico, the Great Lakes and certain other navigable waterways. The charts, over 1100 in total, include four major series. They range from large scale Harbor Charts, showing detailed water depths and important cultural data of U.S. maritime cities to medium and small scale charting of the U.S. continental shelf and adjacent ocean basins. The NOS also publishes over 180 small and medium scale aeronautical charts of the U.S., its possessions and Puerto Rico. Some contouring and spot elevations are used to show relief. However, the untrained map user can easily understand major U.S. land features through these charts by using the excellent tinting and shading techniques employed to portray relief. General cultural data and natural features are well portrayed.

NOS has substantially increased its publication of thematic mapping in recent years. Among the most important is a series of bathymetric mapping at 1:250,000 of the U.S. coasts. These are of particular interest for environmental management decisions along our coasts. The NOS also publishes tidal charts of important harbors and estuaries, and maps indicating the horizontal and vertical control network upon which the accuracy of our nation's mapping depends. Recently it has begun publication of a Sea Maps series showing ocean depths, magnetic and gravity data, all of which are of substantial use in mineral exploration.

Full or partial NOS depositories are available to libraries in the United States which can provide evidence of adequate storage capacity, and agree to give public access to revised charts as furnished.[8] For those libraries which need not accept such substantial responsibilities, the index maps for NOS publications can be obtained free from NOS Distribution Division, (C-44), in Riverdale, Maryland 20840. Some depository libraries can be found in the map library directory. The listing will read "USC & GS", the initials of a predecessor agency.

The U.S. Geological Survey

Let us now consider the U.S. Geological Survey, often referred to as USGS. Its mapping, geodetic, and related activities were funded in fiscal 1972 at about 66 million dollars.[9] In many ways it is the most important federal depository mapping agency discussed in this paper. First of all, it publishes some 55,000 maps in a rich variety of scales and subjects. Of this total, about 44,000 are map depository items.[10] A full depository, established some years back will probably find considerably more than 44,000 maps in its collections due to the USGS revised map program. Second, it is by far the most important publisher of topographic mapping of the United States, its dependencies and Puerto Rico. Third, it has established the largest number of depository libraries of any federal mapping agency - some forty-four in California alone.

The USGS depository mapping program excludes its open-file maps, that is, maps in preliminary form or of limited interest. These are available for inspection and reproduction at the three libraries of the Survey, and, on a selective basis, at other locations.[11] It also excludes maps which are issued solely for USGS text publications, and certain special cooperative project mapping. What remains for full map depositories is a large publishing program running at about 4,000 to 5,000 maps a year.

The core of the depository is the topographic map, the basic document in a map library for any terrestrial area. These range from small scale mapping series at 1:1,000,000, through medium scales at 1:500,000 and 1:250,000, to the larger scale quadrangles published mostly at 1:62,500 and 1:24,000. Only the 1:250,000 scale series, in various degrees of accuracy, covers all the United States. As important as this scale is, the greatest achievement of the USGS can be found in its larger scale maps. Covering around 90% of the 50 states, Puerto Rico, the U.S. Virgin Islands, Guam and American Samoa in some 39,000 sheets, USGS hopes to complete this larger scale coverage for the entire area by 1978.[12] The uses of these scales by researchers are legion, ranging from national planning and resource inventories to intense local use by the citizenry, and academicians from every discipline. It is a particular tragedy that USGS topographic mapping has seldom received the annual funding needed to carry out its mandate. Unfortunately, even if the agency is allowed to com-

plete its program by 1978, many of the maps available will be out of date or at insufficient scale for national and local purposes.[13]

The thematic mapping of the USGS includes geologic maps at large and small scales, mineral resource maps, hydrologic maps and geophysical maps. Recently, experimental land-use mapping has begun to be published by USGS, and the Survey hopes to begin regular publication at 1:250,000 for the entire United States. Large scale land-use mapping for selected areas is also proposed.[14] Included in the Miscellaneous Investigations series are many surprises from an agency principally concerned with U.S. mapping. These include topographic maps of Saudi Arabia and Libya, geologic mapping of Indonesia and the Moon, and even a medium scale map set of Liberia.

USGS partial or full topographic depositories are granted according to conditions similar to those outlined by the National Ocean Survey. Geologic and hydrologic maps are ordinarily sent only to those academic libraries offering a degree in geology. The USGS depository supplies currently published mapping. Most maps published prior to the establishment of a depository must be purchased. Occasionally the USGS will provide a previously published core collection of the local area in establishing a new depository.

For those who would like to be able to refer users to USGS materials, free index maps are available for topographic mapping of each state. These publications (and their subsequent revisions), also contain an up-to-date list of USGS map depositories. All thematic mapping published by the agency is listed in its free Publications of the Geological Survey, with supplements, and for each state in its Geological and Water-Supply Reports and Maps.

Conclusion

In concluding this general review of major federal map depositories, several points are evident. First, the availability of federal map and chart depositories is critical to the effectiveness with which map libraries in the United States can respond to a growing demand for information. Second, libraries which experience only sporadic demand for such information can obtain free index maps for all unclassified, major federal depository mapping, excluding the DMA Topographic Center. For \$2.25 extra, they can add the publicly distributed index maps of the DMA Hydrographic Center. (Surely, as reference works to some very important documents, their acquisition cost adds up to one of few great bargains left). Third, libraries which really need depositories, will find federal civilian agencies generous in response.

Federal depositories for maps and nautical charts of foreign areas remain a major disappointment. Perhaps from the overview presented in this paper we ought also to conclude that it is time for the Defense Mapping Agency to re-examine its policy on depositories. Depositories making available DMA mapping and charting to a wider spectrum of researchers are essential, if for no other reason than the fact that environmental problems know no territorial limit. Man has demonstrated his world-wide power to destroy those fragile systems of nature upon which he is utterly dependent. Yet, he lacks the knowledge needed to save them. Mapping alone can not supply such knowledge nor the wisdom to use it, but it is an essential source of the data upon which both are built.

References

1. The Federal Mapping Task Force lists the fiscal 1972 budgeted activities for domestic mapping, charting and geodesy (MC & G) and related activities

at \$446.8 million. (U.S. Office of Management and Budget. Federal Mapping Task Force. Report of the Federal Mapping Task Force on Mapping, Charting, Geodesy and Surveying July, 1973, Washington, D.C. U.S. Government Printing Office, 1973, p.2). The Defense Mapping Agency's current budget is reported at \$160 million. (Howard W. Penney, "A Brief History of the Defense Mapping Agency", Photogrammetric Engineering, vol. 34, no. 5, 1973, p.469). During fiscal '72 less than 10 percent of DMA's budget was spent on domestic MC & G. The total reported expenditures for mapping, charting, and geodesy thus add up to over \$.5 billion and do not include additional classified MC & G activities.

2. Mapping vocabulary is as dynamic as other parts of the English language. Variations in meaning exist and change over time. Most definitions used in this section follow, although not completely, the definitions listed in: U.S. Defense Mapping Agency, Glossary of Mapping, Charting and Geodetic Terms, third edition, Washington, D.C.: 1973.
3. Penney, Howard W. "A Brief History of the Defense Mapping Agency", Photogrammetric Engineering, vol. 33, no. 5, 1973, p.469.
4. Penney, Howard W. "DMA Production Forecast", Military Engineer, vol. 66, no.429, 1974, p.23.
5. Nicoletti, Frank T., "U.S. Army Topographic Command College Depository Program", SLA, Geography and Map Division, Bulletin, no. 86, December 1971, p.2 - 3.
6. Nicoletti, Frank T., op cit, p.3.
7. U.S. Office of Management and Budget, loc. cit.
8. Personal communication from Raymond Wilcove, Public Affairs Officer, National Ocean Survey.
9. U.S. Office of Management and Budget, loc. cit.
10. Personal communication from Lewis D. Brown, U.S. Geological Survey, Reston, Virginia.
11. For current listings of USGS libraries and offices see: U.S. Geological Survey. Geological Survey Research [year], published in its Professional Papers.
12. McKelvey, V. E., "New Activities at the Geological Survey," Military Engineer, vol. 66, no.429, Jan-Feb., 1974, p. 20.
13. U.S. Office of Management and Budget, op. cit., p.73.
14. McKelvey, V.E., loc. cit.

[EDITOR'S NOTE: A recent development, since Mr. Sivers wrote the above article, has been reported to the Information Bulletin: DMA has announced to its Depositories that it will add to the items it sends regularly certain charts published by its HYDROGRAPHIC CENTER and its AEROSPACE CENTER. Details are not known at this point, but the Information Bulletin will report when more information become available.]

*announces a Master's Degree Program for***MAP LIBRARIANS**

This country has witnessed a phenomenal growth in map collections over the past two decades. Although maps are primarily utilized by geography students, they are becoming increasingly important to those studying history, ecology, geology and urban planning. Map centers to service these needs have developed in numerous libraries, but there is one missing element: librarians who have specific skills to effectively operate them.

At Western Michigan University, the School of Librarianship, in conjunction with the Department of Geography and the University Map Library, is now attempting to meet the need for qualified map librarians. A graduate program leading to the Master of Science in Librarianship (M.S.L.) degree has been developed which combines study in library science with courses in map interpretation. Ample opportunity to study and work with maps is offered in the University Map Library. This collection contains close to 150,000 maps, 1,000 atlases and related materials. The individual who completes the course of study will have preparatory work in administration, acquisition, organization, processing and interpretation techniques and will conclude his program with an internship experience under a qualified map librarian.

CURRICULUM

The thirty-six hour program at Western's School of Librarianship will include basic and advanced courses in library science and geography. The librarianship program requires work in administration, subject bibliography, special libraries and advanced cataloging. A special one week orientation in the Geography Department will introduce the program and will include sessions on map maintenance as well as an audio-tutorial introduction to the interpretation of maps. Supportive courses in cartography and air photo interpretation are offered by the Department of Geography and arrangements may be made to undertake specialized course work under a member of the staff.

At the conclusion of the program a professional field experience in a map library will emphasize adapting library cataloging and classification to maps, selection practice, and readings in map history and libraries. This internship may be arranged in the Western Michigan University Map Library or in other outstanding map libraries. The Department of Geography also sponsors an internship in the Geography and Map Division of the Library of Congress.

ADMISSION & RESIDENCE REQUIREMENTS

Applicants must be admitted to the Graduate College and the School of Librarianship. Students are expected to have a bachelor's degree from an accredited school or university with a minimum grade point average of 3.0 (B) in the last two years of undergraduate studies and a general liberal arts background. It is helpful to have an academic major in the social sciences with course work in geography.

For further information about admission and program please write:

[The Editor wishes to thank Dr. Louis Kiraldi for this announcement. Dr. Kiraldi, Map Librarian at WMU, adds that "... this opportunity is offered every semester but only for a select few students with sufficient background."]

Dr. Jean E. Lowrie, Director
School of Librarianship
Western Michigan University
Kalamazoo, MI 49001

by

Patricia Moore
Library Assistant and Current Announcements Editor
Map Division, O. Meredith Wilson Library
University of Minnesota, Minneapolis

"News & Views; Notes and News; Announcements and Acquisitions" --- these are phrases beginning to appear on acquisitions lists issued in the Midwest this past year. In most cases, the phrases are indicative of a news column or section that has been tacked on to the acquisitions lists issued by Map Libraries for a number of years.

The University of Minnesota's Map Division has recently celebrated its first anniversary of "news sharing," thus presenting a good occasion for a discussion of the history behind and progress of what was to become the Midwest's first regularly produced "newsletter." Like news columns to follow, Minnesota's was added on to an earlier production--the monthly acquisitions list. A product of the "Map Library" since February, 1966, the currently produced "acquisitions list" is now in its third "edition". The first "edition" contained only books, atlases and serials. The second, beginning in January, 1967, included maps on a selective basis (United States and Canadian topographic quadrangles were excluded). Selected New Acquisitions was the title until the incorporation of a news column in April, 1973. Thereafter, the list was known as Current Announcements and Selected New Acquisitions, thus constituting its third "edition". Part of the former title was retained in order to make the content of the publication evident. During the first year of publication (Volume one), ten numbers in all were issued, July-August and November-December one number each.

The Map Division has always considered the acquisitions list a useful tool. At one time, acquisitions lists from other libraries were valuable sources from which to "select" new maps and atlases. The Map Division's list was, and is currently, sent to a number of other libraries for such purposes. Although the list functions as an acquisitions tool for the librarian, it is also a current awareness source for the public. This latter function, current awareness, is the dominate reason behind the publication of the "acquisitions list" today. The Map Division continues to exchange its list with other libraries; however, incoming lists are primarily valued for the "news" contents.

"News" was first included in the "acquisitions list" in the Spring of 1973 as an experiment. The purpose of this experiment was to test the viability of the list as a news carrier, thus establishing formal communication channels for information exchange on a local level between Map Libraries, and strengthening the usefulness of the acquisitions list as a public relations tool. The basic philosophy in including a news section, organized separately from the acquisitions section, was that the traditional acquisitions section constituted a news item in itself. Therefore, adding other "types" of news--who, when, how, where --to the "what" of the acquisitions part, was seen simply as an act of broadening the news base.

It was assumed if the list were a viable news carrier, public response would tend to support its further publication. Map librarians, particularly

in the "pressless" Midwest, were a target audience for determining the success or failure of the new enterprise. Map librarians in general were singled out as an "experimental group" because their cooperation in producing acquisitions lists--public relations tools--was of value; not because they constituted the "most important" group of recipients for Current Announcements. [1] Map librarians from the Midwest were chosen for geographical reasons, Minnesota being part of the Upper Midwest, therefore representing a geographical kinship. Another reason for selecting the Midwestern area lies in the fact that the largest cluster of medium-to-large sized academic Map Libraries in the United States was situated in this part of the country. [2] However, the area lacked a "publication of an informative character" that was representative of the Midwest as a whole. [3] The need for an area newsletter has never been fully substantiated, though it has been discussed. [4]

It was assumed if the Midwestern map librarians, particularly those active in the publication of acquisitions lists, liked the concept of the informal "newsletter", they would respond by including news sections on their acquisitions lists, thus sharing their "news" with the Map Division. [5] Theoretically, the existence of a large informal news network with actively contributing outposts, had the possibility of becoming a feasible system for communication of problems and trends--as well as local differences--in the field of Map Librarianship. Such a system would require little "political" involvement and a minimum of red tape, thus resulting in the existence of "official", current communication channels for the map librarian.

There were also other reasons and audiences (other than the map librarian) behind the publication of the first issue of Current Announcements. As stated earlier, the primary factor behind the publication of the "newsletter" (hereafter quotation marks deleted), was public relations. The Library's "public", as reflected by the mailing list for Current Announcements, consisted of both departmental and Library units on the University of Minnesota Campus, federal and state agencies, private individuals, and map libraries all over the country and including Canada. [6] "News" in the newsletter is written for all these categories of readers, in order to bring the Library to the attention of the Community which it serves. The Community stretches from the student, faculty and staff member with direct access to the collection, to the individual whose tax dollar supports the acquisition of Library materials. Also included are the state and federal agencies who publish and aid in the location of material, as well as institutions and libraries which depend on one another for services. Therefore, the experiment to test the viability of the acquisitions list as a news carrier rested on the response of the Library's total public, not just a selected audience, for the determination of the success or failure of the project.

Fortunately for Map Division staff members, it was not necessary to take a poll to determine public reaction to Current Announcements. Reactions were manifested in an unsolicited manner; that is, people who had access to, or heard about, the newsletter, contacted the Map Division under their own initiative. In general, reactions occurred in two ways: one, requests to be added to the mailing list; two, comments to news items. In the former case, current mailing list statistics indicate a 225% increase in the circulation of Current Announcements since its appearance in April, 1973. Off-Campus recipients, mainly map librarians, constituted most of this increase. Approximately half of the requests from map librarians came from small-to-medium colleges and universities in the Midwest with either formal, or informal map collections. [7] Prior to April, 1973, most of the acquisitions list mailings were to Campus

addresses, notably the Geography Department. After this date, the increase in Campus mailings was due to requests from various social and natural science departments, as well as Library units. Today, mailings are evenly distributed between Campus and off-Campus addresses. In the future, one would expect the off-Campus circulation to grow at a much faster rate than the Campus, since there is greater potential for growth in the larger area. The changing proportion of recipients of the "acquisitions list", since its initial publication in 1966, reflects the expanded public that makes use of the Map Division today.

Reaction to Current Announcements was also manifested by comments to specific news items. A sampling of the following comments came from immediate library users: "I heard you have some new air photos of Chippewa National Forest; Can you give me some information on laminating maps?--I read you had a machine; I noticed you gave a tour to the Minnesota Geneological Society--can people use maps to study geneologies?" On one occasion, a geography professor doing a review of an atlas came to the Library. He had read in Current Announcements the atlas was now available in two editions, one of which was cheaper than the other. The Map Division had one edition and an advertising leaflet describing the other. It would be interesting to note the professor's comments on the editions in his review. On another occasion, a response from a "non-library" user came from California. The respondent was a map librarian reacting to a notice regarding aerial photographs the Map Division wished to dispose of. He called, requesting more detailed information concerning coverage of Western states.[8] Examples of such responses could go on indefinitely; however, those mentioned should suffice to indicate the public's readiness to respond to developments in the Library when the invitation is extended to them, in this case, in the written form of Current Announcements. Thus, it would seem, applying the "response" criteria indicated by both the increase in demand for the newsletter, as well as the sample comments above, the experiment to broaden the news base by including items (other than the traditional acquisitions), was remarkably successful.

So far, the purpose of the acquisitions list has been discussed, as well as the response to the newsletter idea. No mention has been made of the reasons for developing a news column, other than it was felt new acquisitions were naught but a special category of "current announcements". The decision to experiment with the news column, thus developing a new format for the "acquisitions list", was based on several factors. The most important factor was involved with changing the traditional, and thus limited, content of the acquisitions list. Map Library acquisitions lists usually include only cataloged materials--maps, atlases, and serials. The citations are copied from processing records, call numbers being included.[9] Uncataloged, or "vertical file" materials--aerial photographs, pamphlets, dealer's catalogs, etc.--are often overlooked, not because they are not considered important, but because the processing records are unique for these forms of materials, and they usually are not channeled with regular records for inclusion on the acquisitions list. Other types of materials that might properly be mentioned, belong to excluded groups of matter, such as U.S. Geological Survey or Canadian topographic maps. It is possible to excerpt certain items of interest, such as new orthophoto maps of Minnesota or quadrangles covering an area of special interest such as the Boundary Waters Canoe Area (BWCA). Since most map libraries get these maps, their arrival in the Library is generally a matter of little significance; however, the Library's public may be interested in certain areas included in a shipment of maps. Another category of material that would benefit from inclusion on the acquisitions list is material the Library wishes to dispose of--exchanges. The presence of

a special column in which to list duplicate maps and atlases would be an asset to both the library wishing to withdraw material, as well as the library wishing to acquire. Libraries using acquisitions lists primarily for the purpose of acquiring materials would especially benefit from the existence of formal communication channels for such items.

A final reason for instigating a news column rested on simple curiosity. Since acquisitions lists were exchanged among map libraries, it was always possible to know what kind of materials were acquired where, as well as how the materials were organized. Other information regarding internal operations-- "Do you use special circulation forms for air photos? How do you go about replacing maps received on depository? --staff activities and publications-- "Do you have a brochure describing your collection? What effect do displays have on library users?" --special subject listings or bibliographies-- "Do you keep an address file the public has access to? Who are local dealers for maps of Wisconsin?" --reflect the existence of the Map Library much more accurately than a simple listing of acquisitions. If such information is couched in the right terms, the general public's interest will not be lost. While much of this type of information may take the nip out of convention-going for the map librarian, its gradual dissemination may aid in its manageability.

How much time is spent on the news section? As previously mentioned, the acquisitions section may be compiled from processing records. News, however, must be collected as well as written. Therefore, unless a systematic process is followed, publishing a news section may be a painstaking enterprise. In the Map Division, all staff members, including student assistants, are responsible for collecting and recording news. A special Current Announcements folder is maintained, and when the staff members ascertain he or she has a contribution, they jot down the essentials of their offering, and file it in the folder. For instance, a staff member who reads the Minneapolis Star notices there is an article on the activity of State offices in map sales. She clips the article and inserts it in the folder. Another staff member who is responsible for processing incoming books, notices a popular reference atlas is poorly bound. She checks the atlas, noting the problem section, and files a duplicate processing record in the folder. Another staff member who is trying to replace a map missing from the collection, discovers it is out of print. She records this information, dropping the notation in the folder. Once it is time to publish the "acquisitions list", the offerings are collected and evaluated for inclusion. If the news is current, pertains to maps or aspects of cartography, and is relevant to Minnesota, it is used. If these criteria are not met, the "news" is discarded.

After the news is collected, it must be written. Writing the news section is a chore that becomes easier with practice. The Map Division numbers its announcements, putting the most important either first or last. A short descriptive phrase is employed after the number to introduce the announcement. The phrase may read: New sales agent--the announcement following explains how the Minnesota Geological Survey has recently become a sales agent for topographic maps of Minnesota. The announcement should be short, giving all the essential facts. It should not be a discourse of a philosophical nature, but may be a special column, such as Map user of the Month, or a periodic article, the theme of which is the description of various map collections on campus.

The Map Division's "acquisitions list" has changed greatly in the eight years it has been published. The expanded clientele making use of the Map

Division facilities is accountable for most of the change. At one time, the "map user" represented an esoteric audience whose domain was a specialized body of information. Today, the map world is the domain of the public--the taxpayer not only pays for the maps, he wants to use them. The map librarian has been a specialized audience of the "acquisitions list" for some time. The function of the "list" has also changed in regard to this category of recipient, no longer being intended primarily as an acquisitions aid. A change in title, from Selected New Acquisitions to Current Announcements and Selected New Acquisitions in April of 1973, reflects the new function of the "acquisitions list" -- a device to facilitate communication among map librarians, especially those in the Midwest.

COMMENTS

1. Quantitatively they are the most important, however, constituting 37% of the recipients.
2. Reference was made to R. W. Stephenson's MAP: "Map Collections in Anglo-America, 1969", in the front of Special Libraries Association, Map Collections in the United States and Canada, 2nd ed., 1970.
3. The ideal was more the Western Association of Map Libraries, Information Bulletin, than the more academic Geography & Map Division Bulletin.
4. This idea was discussed with David Cobb, Lewis Armstrong, Mai Treude, and myself, among others.
5. The Universities of Kansas and Illinois, Champaign-Urbana, included "News & Notes" sections.
6. The "acquisitions list" is sent only to parties that request it directly. The audience is therefore self selected.
7. Surprising, if these schools requested the "List" for acquisitions purposes, since one was available for such purposes long before the issuance of the Current Announcements edition!
8. The result of which is in the "Gifts & Exchange" section of WAML Information Bulletin, June 1974, Vol. 5, #3, p.27-28.
9. This is the method employed by the Map Division. There may be some variation from library to library.

APPENDIX

Summary of sources for news gathering employed in the Map Division:

- A. New acquisitions: 1) Budgeted 2) Unbudgeted
- B. Annotations to the above: 1) Excerpt on particular ti. 2) USGS or other uncat items, incl. air photos 3) Gifts
- C. Displays; tours
- D. Map making activities or special reports prepared by Depts., etc.
- E. Internal operations and procedures
- F. Staff activities, conferences, etc.
- G. Excerpts from journals, announcements, that would be of interest to public
- H. Exchange items
- I. New library publications
- J. Public use; referral services
- K. Special columns or features

NEW MAPPING OF WESTERN NORTH AMERICA

Contributions by: Mary Blakeley, Phil Hoehn, Susan Trevitt, and The Editor.

ARCTIC REGION

American Geographical Society

Map of the Arctic Region. 1:5,000,000 50 x 60 inches. 10 colors. \$12.00

Bathymetric data supplied by Dr. Bruce Heezen; scale departure diagram by O.M. Miller. ERTS imagery utilized. Elevation and depth shown by contours and hypsometric tints. Streams, inland lakes, bathymetry, political boundaries, towns, roads, railroads, airports, and other cultural features shown. Limits of trees, permafrost, and sea ice depicted.

All orders must be prepaid, U.S. Currency, no discounts; folded copies or unfolded copies available (except the latter not available outside the U.S.).

AGS, Broadway at 156th Street, New York, NY 10032.

CANADA

Canada. Department of Energy, Mines and Resources. Earth Physics Branch. Gravity Division.

Bouguer Anomaly Map of Canada. Third edition. 1974. 1:5,000,000. \$3.00 (rolled or folded) in Canada and the U.S.A. and \$5.00 in all other countries.

Orders to: Canada Map Office, 615 Booth Street, Ottawa, Canada, K1A 0E9
Cheques and money orders should be made payable to the Receiver General of Can.

Canada. Environment Canada. Environmental Management Service. Lands Directorate.

Canada Land Inventory. Map series covering agriculture, forestry, wildlife waterfowl, recreation, wildlife ungulates, and land-use planning. These maps are issued in folio format. Priced at 50¢ for each map, the titles are as follows: "Soil Capability for Agriculture", "Land Capability for Forestry", "Land Capability for Recreation", "Land Capability for Wildlife-Ungulates", "Land Capability for Wildlife-Waterfowl", and "Land Capability Analysis".

A March 1974 Index is available which indicates current status of these series. Canada Map Office, 615 Booth Street, Ottawa, Canada K1A 0E9

UNITED STATES

American Indians in the United States: 1970, by T. A. Jones, Jr. A two-color map (red & black) 34 x 22 inches. Shows distribution of United States Indians by proportional circles. Based on 1970 Census. \$1.75 incl. shipping & handling.

University Bookstore, University of Northern Colorado, Greeley, Colorado 80639

ALASKA

Base Map of the Aleutian-Bering Sea Region. By David W. Scholl, Tau Rho Alpha, Michael S. Marlow, and Edwin C. Buffington. Reston, VA; U.S. Geological Survey, 1974. Its *Miscellaneous Investigations Series I-879*.

The principal map (@1:2,500,000) covers the Aleutian Islands, Kamchatka Penin-

sula. Inset map is an Orthographic Drawing [a speciality of Mr. Alpha] which depicts the undersea canyons and trenches, with a vertical exaggeration of x10. Contour interval below sea level starts at 200 meters, ticks show direction of slope. Text printed on map gives data sources. 75¢ For sale by U.S. Geological Survey, Fairbanks, Alaska 99701; Denver, Colorado 80225; or Reston, Virginia 22092.

ARIZONA [all entries courtesy of Mary Blakeley, Head, Map Collection, University of Arizona, Tucson]

[format: Amazing Arizona camping and campgrounds
 TITLE:
 SCALE: not given
 DATE: 1973
 PRODUCER: Travel Information Section, Arizona Dept. of Economic Planning
 and Development, 1645 West Jefferson, Phoenix, AZ 85007
 COST:] Free

Bouguer gravity anomaly map of Arizona
 1:1,000,000
 1973
 Laboratory of Geophysics, Dept. of Geosciences, University of
 Arizona, Tucson, AZ 85721
 \$2.00 (ozalid print)

Census tracts in the Tucson, Arizona SMSA, 1970 Census of Population and
 Housing.

1:1,000,000 and 1:85,000
 1972

U.S. Government Printing Office, Washington, DC 20402

General soil map of Graham County, Arizona

1:500,000
 1973

U.S. Soil Conservation Service, Federal Building, 230 North 1st Ave.,
 Phoenix, AZ 85025

Free

General soil map of Greenlee County, Arizona

1:500,000
 1973

[same as above]

Free

General soil map of Maricopa County and Gila River Indian Reservation,
 Arizona

1:500,000
 1973

[same as above]

Free

General soil map of Pima County, Arizona

1:500,000
 1974

[same as above]

Free

ARIZONA (continued)

Grand Canyon National Park and vicinity, Arizona. Shaded relief edition.
 1:62,500
 1973
 U.S. Geological Survey, Distribution Section, Federal Center, Denver, CO;
 80225
 \$1.75

Hearne Brothers official map of greater Phoenix metropolitan area.
 1:35,000
 1973
 Hearne Brothers, 25th Floor, First National Bank Bldg; Detroit, MI 48226
 \$152.50

Hearne Brothers official polyconic projection map of Arizona.
 ca. 1:500,000
 1974
 Hearne Brothers [same as above]
 \$152.50

Mining districts and mineral deposits of Arizona (exclusive of oil and gas).
 1:1,000,000
 1973
 Charles A. Mardirosian, 1904 East 17th South, Salt Lake City, UT 84108
 \$5.50

The natural vegetative communities of Arizona.
 1:500,000
 1973
 Arizona Resources Information System, 3500 North Central, Suite 118,
 Phoenix, AZ 85012
 FREE

Official road map, County of Pima, Arizona.
 1:125,000
 1972
 Pima County Engineer, Pima County Highway Dept., 1313 South Mission Road,
 Tucson, AZ

Orthophoto quadrangles of the State of Arizona.
 1:24,000
 1972 - to date
 Arizona Resources Information System [loc. cit.]
 \$8.50 per quadrangle (photographic copy)

State of Arizona subsurface temperature map. Prepared by J. S. Scurlock and
 J. N. Conley.
 ca. 1:1,000,000
 1972
 Arizona Oil and Gas Conservation Commission, Room 202, Capitol Annex East,
 Phoenix, AZ 85007
 Free

ARIZONA (continued)

Topographic map of the Organ Pipe Cactus National Monument, Arizona.

1:62,500

1972

Southwest Parks and Monuments Association, Organ Pipe Cactus National Monument, Ajo, AZ 85321

\$1.50

Tucson area federal aid systems.

1:125,000

1973

Pima Association of Governments, Transportation Planning Program, 215 North Court Avenue, Tucson, AZ

Free

CALIFORNIA

Geology and Geologic Hazards of the Novato Area, Marin County, California.

By Salem J. Rice, assisted in geophysical studies by Gordon W. Chase.

Sacramento, California Division of Mines and Geology, 1973. *Preliminary Report 21.*

Maps in pocket: Plate 1: Geology of portions of the Novato Area, Marin County, California. Scale 1:12,000.

Plate 2: Interpretation of the relative stability of upland slopes in portions of the Novato Area. 1:12,000

Plate 3: Earthquake risk in parts of the Novato Area. Estimates of general response of various geologic settings to an earthquake of approximately Magnitude 8, with epicenter located in the Northern San Francisco Bay Area. 1:12,000

Plate 4: Seismic and magnetic traverses of the Bay plains in Southeastern Novato.

CDMG, P.O. Box 2980, Sacramento, CA 95812

\$4.00

[The following entry courtesy of Phil Hoehn, Bancroft Library, UC Berkeley.]

FACSIMILE OF GODDARD'S MAP OF CALIFORNIA

A black and white full scale reproduction of the following map is available from the Friends of the Bancroft Library.

CALIFORNIA. 1857. 1:1,600,000.

Goddard, George Henry, 1817-1906.

Britton & Rey's map of the State of California ... by George H. Goddard, C.E. San Francisco, Britton & Rey, 1857; (Berkeley, Calif.) Friends of the Bancroft Library (1969) 29.5 x 24in. (75 x 61cm.)

The map was originally published in Albert Shumate's The Life of George Henry Goddard (Berkeley, Friends of the Bancroft Library, 1969, fold. in pocket).

The map, which will be shipped rolled in a mailing tube, is available for \$3.00 (plus sales tax for California institutions).

Orders, which must be accompanied by payment, may be sent to:

The Friends of the Bancroft Library
The Bancroft Library
University of California
Berkeley, CA 94720

CALIFORNIA (continued)

A Rapid Transit System for Los Angeles County.

Scale not given. A multi-colored brochure/map created in September 1974 for the November 1974 election to explain the ballot Proposition A before the voters.

Southern California Rapid Transit District, Public Information Department, Room 500, 1060 S. Broadway, Los Angeles, CA 90015.

Free

OREGON [Contributions by Susan Trevitt, Map Library, University of Oregon]

Oregon State Highway Division. Index and Price List to general highway series, County Maps. July 1974.

Gives latest revision date, indicates revision underway, etc.

Map Distribution Unit, Room 17, State Highway Bldg., Salem, OR 97310.

Free

Bureau of Land Management [Portland][i.e., U.S. Bureau ...]

Master unit map (series) each \$1.00 @1:126,000 1)North $\frac{1}{2}$ of South Coast
1970

2) Douglas South Umpqua 1970

3) Upper Willamette 1971

4) Siuslaw 1970

U.S. Bureau of Sport Fisheries & Wildlife

8 x 10" maps of Oregon's wildlife refuges - scales vary - Free

Ankeny National Wildlife Refuge 1972; Basket Slough N.W.R. 1972; Cold Springs N.W.R. 1977; Hart Mountain N.W.R. 1977; Lewis & Clark & Columbia White Tailed Deer National Refuges 1972; Lower Klamath N.W.R. 1937; McKay Creek N.W.R. 1977; Malheur N.W.R. 1972; Umatilla N.W.R. 1977; Upper Klamath N.W.R. 1977; William L. Finley N.W.R. 1977

State Supervisor, U.S. Bureau ..., 1500 NE Irving, Portland, OR

U.S. Forest Service. Pacific Northwest Region. [Free]

1. Deschutes N.F. 1:125,000 1971; 2. Malheur N.F. 1:125,000 1968;
3. Mt. Hood N.F. 1:125,000 1967; 3b. Mt. Hood Wilderness Area 1:62,500
1965 contour edition
4. Ochoco N.F. & Crooked River N. Grassland 1:200,000 1968.
5. Rogue River N.F. 1970; 5a. The Rogue River Wild & Scenic 1971;
6. Siskiyou N.F. 1968; 7. Siuslaw Resource Area 1969; 8. Umatilla N.F.
9. Umpqua N.F. 1970; 10. Willamette N.F. 1969; 11. Wallowa-Whitman N.F.
1968;
1964;
12. Eagle Cap Wilderness 1971 contour 1:62,500; 13. Winema N.F. 1968;
14. Three Sisters Wilderness 1969 contour 1:62,500; 15. Mt. Jefferson
Primitive Area 1968 1:62,500 contour; 16. Mt. Jefferson Wilderness
1972 1:62,500 contour; 17. Mt. Washington Wilderness 1974 1:62,500
contour; 18. Pacific Crest National Scenic Trail: Oregon 1971.

Siuslaw National Forest, Helo Ranger District.

Cascade Head - Salmon River Area. 1972. 1:31,680 Free

[area under consideration by U.S. Congress as Cascade Head Conservancy]

U.S. Forest Service. Pacific Northwest Region, P.O. Box 3623, Portland, OR
97208

OREGON (continued)

Oregon. State Land Board.

Tidelands of Oregon Estuaries. ca. 1:20,000 (varies) 1970's 16 sheets
 Tidelands Ownership maps of Oregon Estuaries " " 12 sheets

502 Winter St. NE, Salem, OR 97310 Price unknown.

Oregon. State Water Board.

Drainage Basin Series. 1970- Scales vary. Cost?

- 1) North Coast map #1.6 1972; 2) Willamette map #2.6 1964;
- 3) Deschutes map #5.6 1973; 4) John Day map #6.6 1974;
- 5) Rogue map #15.6 1970; 6) Umpqua map #16.8 1974;
- 7) South Coast map #17.6 1971; 8) Mid-Coast map #18.6 1972.

Oregon State Water Resources Board, 1158 Chemeketa NE, Salem, OR 97310

MAP LIBRARIANSHIP JOB OPENINGS*

LIBRARY OF CONGRESS Geography and Map Division, Processing Section.

Librarian (Cataloger) GS-9 (\$12,167 - \$15,821) Temporary until Jun. 3, 1975. Posting opened June 13, 1974; CLOSED June 20, 1974.

Educational Requirements: Bachelor's degree in geography and 2 years of related experience; or BA degree in geography and MLS in Library Science.

Qualifications: Knowledge of the LC and AA cataloging rules; ability to read and interpret maps with respect to geographical coordinates, scales, significant dates and authorities; acquaintance with bibliographic tools and cataloging techniques; accurate typing at a moderate speed as demonstrated by a typing test.

An adequate amount of additional experience or training, as appropriate, may be considered in lieu of qualifications specified.

STATE UNIVERSITY OF NEW YORK AT BUFFALO

Map Librarian—To organize and maintain the map collection in the Science and Engineering Library by cataloging, classifying, and indexing all miscellaneous depository items and by inventories of the depository collection (E.G., A.M.S., and U.S.G.S. maps). Also may conduct seminars in the arrangement and use of the map collection and assist library users by instruction and information regarding library reference materials. MLS from an accredited library school required. Previous experience in the organization and maintenance of non-traditional collections as well as in map work desirable. Rank and Salary: Assistant Librarian, \$9,350-\$11,250. Please submit resume to: Dr. Arthur Cole, Libraries Personnel Officer, State University of New York at Buffalo, 300 Lockwood Memorial Library, Buffalo, New York 14214. An affirmative action/equal opportunity employer.

from *Special Libraries*, Aug. 1974

* Openings announced here are for informational purposes only, on the premise that readers are interested in employment trends in map librarianship. The positions are not necessarily available at this time, and readers should expect the possibility that the particular vacancy has been filled.

PUBLICATIONS OF RELEVANCE

Allen J. "Tommy" Thompson, WAML Member and owner/operator of the Map Centre, 2611 University Avenue, San Diego, CA 92104 (phone (714) 291-3830), whose motto is "If you can't find it on our maps ... IT'S LOST!", has submitted the following information to indicate the extent of the Map Centre stock and services:

- = about 3,000 maps in stock: USGS topo coverage 7½' & 15' coverage of California (except the Central Valley); same for ¼ of Arizona; 1:250,000 quads of Calif-Ariz-Nev-Utah-Oregon; State topos @ 1:500,000 of all western states; special sheets of National Parks of all western states.
 - = Geologic maps & information - all of Calif-Ariz-Nevada.
 - = U.S. National Ocean Survey nautical charts - west coast to San Francisco, incl. Hawaii
 - = U.S. National Ocean Survey aeronautical charts - sectionals of all western states; ONC's for western states, Baja, Mexico, and Central America.
 - = American Map Co. - stocks a large selection of business & wall maps.
 - = Rand McNally Co. - same as for American Map Co.
 - = foreign countries - all types of maps & travel guides - Michelin, Kummerly-Frey, etc. Stock about 60 foreign city maps, mostly European.
- Baja, Mexico - a very complete line of maps and guide books, and presently the Map Centre is attempting to stock the new Mexican topographic series @ 1:50,000.
- = 3-D Maps: Nystrom - World, U.S., California
Kistler - all available
Hubbard - Plastic relief maps (old AMS variety) @ 1:250,000:
California - North to Sacramento, Grand Canyon, and Hawaii

A recent inquiry to the Map Centre for coverage of the Mexican islands off the San Diego coast, Los Coronados Islands, produced a guide by that title which was written by Helen Ellsberg, La Siesta Press, 1970, \$1.00. Although this booklet does not contain a detailed topographical map of the islands, neither does any other publication or map. Nautical charts are of little help in this case. The booklet does have some excellent photos of the islands, however, and a more than adequate description, and history. The Coast Pilot of 1889 [Davidson, Geo., Washington, GPO, 1889, 4th ed.] gives a briefer description and a sketch map showing cross sections for shape of the islands and elevation.

Inquiries are welcome.

Larry Cruse, WAML Member from the Map Section, UC San Diego University Library, has also provided much material for notice of all Members and readers of the Information Bulletin. The first item regards maps of Mexico:

Map of Tijuana; Map of Ensenada; Map of Mexicali. There is no scale, but the sheets are so large they must be folded to fit in a map drawer. All are backed by an outline map of Baja, which looks like Senterfitt's 'Complete Map of Baja'. All are black and white and are U. S.\$3.00 each. Available from: Editora Tijuana Tours, APDO. Postal 754, Tijuana, B.C., Mexico.

More to follow ...

"Photographic copies of old out-of-print maps may be ordered from the Chief, Map Information Office, Geological Survey, National Center (505), 12201 Sunrise Valley Drive, Reston, VA 22092. There is a charge of \$1.00 per copy for standard quadrangles and an additional charge for larger special-size maps."

European Community Information Service.

The European Community in maps. Bruxelles, [1967]. 12 p. maps. *Free.*
[Belgium, France, Germany (Federal Republic), Italy, Luxembourg, Netherlands.]

List of Maps: 1. Administrative region and units. 2. Density of Population. 3. Agriculture I: Land utilization and main crops. 4. Agriculture II: Live-stock and fishing. 5. Energy. 6. The nuclear industry. 7. Industry I: Iron and steel and selected branches of engineering. 8. Industry II: Major industrial regions and distribution of manpower by activities. 9. Transport I: Railways and navigation. 10. Transport II: Roads and civil aviation. 11. External trade. 12: Associated overseas states and territories.

Available from: European Community Information Service. 2100 M Street NW, Suite 707, Washington, DC 20037. *Free.*

San Diego County Planning Department. San Diego, California.

The Cartographic Services Section, 1600 Pacific Highway, San Diego, CA 92101

This public agency produces maps of the San Diego County depicting hundreds of special subjects, either as mylar overlays or as basemaps. The title list shows which subjects are available for which of the 22 quads that cover the County; e.g., Ambulance Districts overlay is available on quads 7, 8, 13; Fog Zone is available on quads 1, 7. They apparently have an efficient filing system for the overlays; e.g., a decimal system that groups all overlays of the same general subject together: section 900 Environmental includes 126 overlays - for example - 902.00 Public Libraries; 953.01 Epicenters; 960.68 Vacant Land; etc. The groups are: 100 Culture; 200 Hydrography; 300 Topography; 400 Political Boundaries; 500 Special Districts; 600 Indexes; 700 National Forest; Parks; Reservations; 800 Titles, Legends; 900 Environmental. Prices vary according to the type of map, material it is printed on, number of overlays required - from \$2.00 per sheet to \$72.74 per sheet (for a color product).

Larry Cruse reports that the maps are revised on a regular schedule. The maps are better quality than the USGS topographical sheet because the usual pink color for urban area is not used, every street is shown here.

The University Library Map Section at UC San Diego has received, *free upon request*, a resources atlas of Thailand, entitled Changwat Nakhon Phanom (1969) from the Engineering Agency for Resources Inventories, U.S. Department of the Army, 4701 North Sangamore Road, Washington, DC 20016. The table of contents lists 71 pages of text, 74 maps, covering 30 different subjects from Physical Resources, Human Resources, Social and Economic Infrastructure; the text is in both English and Thai.

Ed Thatcher has secured for future review in the Information Bulletin the following atlas:

Mairs, John W. and Eugene A. Hoerauf

The Puget Sound Region: a portfolio of thematic computer maps. Bellingham, WA; Center for Pacific Northwest Studies, 1974. Occasional Paper Number Three. \$2.95

Nineteen map subjects are depicted on 36 pages, two maps per subject (except for the first map which indicates the location of the Twelve County Study Region. Available direct from the Center at Western Washington State College, Bellingham, WA 98225.

Evelyn Woodruff, WAML Member and co-compiler of the in-progress WAML Union Catalog of Sanborn Maps, has provided the following citation of a research paper:

Adams, Ann. A Survey of the Status of the Map Collection in Selected Public Libraries in Santa Clara County, Calif. 1972. 68 p. (Research Paper #262, San Jose State University, School of Librarianship).

All research papers are kept in the departmental collection, and inquiries may be addressed direct to the School of Librarianship.

Oregon State University Press has announced the publication of the 5th Edition of the ATLAS OF THE PACIFIC NORTHWEST, edited by Richard Highsmith.

Entirely revised, with more than 200 maps and charts -- nearly twice as many as the 4th edition (1968). All new text and extensive graphics, new historical section, 40 pages of new photographs of resources, land forms, agriculture, forestry, industry commerce and recreation. Emphasis is on resources and development of Oregon, Washington, and Idaho.

Oregon State Univ. Press, P.O. Box 689, Corvallis, OR 97330. Cloth \$13.50

The American Cartographer. Volume 1, No. 1, April 1974. This is an official publication of the American Congress on Surveying and Mapping, and is devoted to the advancement of cartography in all its aspects. Editor is Prof. Arthur H. Robinson, Associate Editor is Prof. Judy M. Olson, and Review Editor is Prof. H. J. Steward. Semiannual; U.S., Canada, Mexico - \$7.00 per year; all other countries - \$8.00 per year.

The stature of articles appearing in the first issue is represented by "Carto-Bibliographical Description: The Analysis of Variants in Maps Printed from Copperplates", by Prof. Coolie Verner.

The March 1974 Newsletter of the Association of Canadian Map Libraries contains a very useful model for an examination or assignment for prospective employees. Entitled "Training a Map Library Assistant", it is a series of 15 questions (with answers) used by Mrs. Anne Piternick in the School of Librarianship, University of British Columbia.

[The Newsletter is available only to Members; Membership dues are for the calendar year: Active (full-time Canadian map librarians) \$7.50; Associate (anyone interested) \$5.00; Institutional \$15.00. Members receive the annual conference Proceedings, as well as the Newsletter. Enquiries may be addressed to the ACML, c/o National Map Collection, Public Archives of Canada, 395 Wellington Street, Ottawa, Ontario K1A 0N3. The March 1974 Newsletter is Number 14, and Number 15 was published in May 1974, both edited by Frances Woodward of the University of British Columbia [who, we are happy to say, is a Member of WAML].

Directory of Map Collections in Australia, compiled by N. M. Rauchle and P.A.G. Alonso. First Edition, February 1974. Melbourne, State Library of Victoria.

Patricia Alonso offers, on a first come, first served basis, copies of this directory free. State Library of Victoria, 328 Swanston Street, Melbourne, Vic., Australia 3000.

The Directory constitutes the first product of a voluntary private survey of map collections in Australia which Mrs. Rauchle began in 1973. During her absence abroad, Mrs. Alonso continued and edited the survey so that this first edition could be made available to the second annual Seminar and Workshop of the Australian Map Curators Circle, 27-28 February 1974.

Benagh, Christine L.

100 keys: names across the land, by Christine Fletcher. Nashville, Abingdon Press, 1973. 288 p. illus. 24 cm. \$5.95. History and legends associated with two places in each of the Fifty States. 1. United States - History, Local - Juvenile literature.

Berlin, Graydon Lenis.

Application of aerial photographs and remote sensing imagery to urban research and studies, by G. Lenis Berlin and Williams W. Ray. Monticello, Ill., Council of Planning Librarians, 1970. 16 p. (Council of Planning Librarians. Exchange bibliography, no. 119).

Bristol Symposium on Remote Sensing, 1972.

Environmental remote sensing: applications and achievements. Papers presented at the Bristol Symposium on Remote Sensing, Department of Geography, University of Bristol, 2 October, 1972. Edited by Eric C. Barrett and Leonard F. Curtis. London, E. Arnold; New York, Crane, Russak, 1974. vi, 309 p. illus. (part col.), maps. 24 cm.

Butchart, Harvey.

Grand Canyon treks; a guide to the inner Canyon routes. Glendale, CA; La Siesta Press, 1970. 72 p. illus., maps.

Canada. Department of Energy, Mines and Resources. Departmental Map Library.

Some Canadian map production agencies and sources of their mapping information. Project 73-8-1. Ottawa, 1973. 44 p.

Lorne Leafloor, Head, Departmental Map Library, explains in the introduction that a questionnaire sent to 166 mapping agencies in Canada was in response to a request from the Topographical Planning Office for information on the use being made of Canadian National Topographical maps in the map production field. Of the 116 replies, 42% indicated that they produce maps. The results are produced here in tabular form. A list of agencies that do produce maps is included, as well as those who do not, and those who did not respond to the questionnaire. Samples of the questionnaires, in both English and French, are given. The results were compiled by Miss Heathcote of the Departmental Map Library.

Canada. Department of Energy, Mines and Resources. Surveys and Mapping Branch.

"Everyone should be able to use a map; the object is to form a mental picture of the ground." Ottawa, 1972. S & M Misc. Ser. 72/2. Copyright, Information Canada, Ottawa, 1974. Cat. No. M52-3472.

An eight-panel brochure designed for the uneducated map user. Explains the conventional signs and symbols used on topographic maps produced by this agency, what "scale" is and how to use it, what contour lines are, bearings, grid coordinates, and map orientation, and how to follow a compass bearing.

Canada. Public Archives. National Map Collection.

Atlases published in The Netherlands in the Rare Atlas Collection. No. 1 in a provisional series describing the atlases in the National Map Collection by country of origin. Compiled and edited by Lou Seboek. Ottawa, Public Archives of Canada, 1973. Copyright by Information Canada, Ottawa, 1973. Cat. No: SA2-6673. Foreword by Theodore E. Layng. Introduction by Lou Seboek.

xviii, 132 p. 28 cm. Includes bibliography. Title page and introductory material in French and English.

Canada. Public Archives. National Map Collection.

French Atlases in the Rare Atlas Collection, Volume 1. Second in a provisional series describing the atlases in the National Map Collection. Compiled and edited by Lou Seboek. Ottawa, Public Archives of Canada, 1974. Copyright, Information Canada, Ottawa, 1974. Cat. No.: SA2-71/1974. Introduction by Lou Seboek. Prefatory material in French and English. Introduction includes biographic material on atlas compilers, cartographers, publishers, etc.

xvi, 186 p. 28 cm.

Canada. Public Archives. National Map Collection.

List of map series in the Foreign Section; Volume IV: America, ocean islands, and the world. Compiled by Vivien M. Cartmell, Map Research Officer, Foreign Section. (This is the final list in the series. It is actually a Union List of maps held in series by eighteen (18) Canadian map libraries, in addition to the National Map Collection.) Ottawa, Public Archives of Canada, 1974.

52 p. (i.e., 104 p.) 28 cm. Free.

Canada. Public Archives. National Map Collection.

List of gazetteers in the Foreign Section. Compiled by Karen Lochhead. Second edition compiled by Vivien Cartmell. Ottawa, Public Archives, 1974.

pp. 1-25 - English arrangement; pp. 26-47 - French arrangement. 28 cm.

THE NATIONAL ATLAS OF CANADA, fourth edition, revised, is published this month by Macmillan of Canada, 70 Bond Street, Toronto, Ont., M5B 1X3. Published in bound form, this is essentially the same atlas as the 1973 edition issued as loose sheets in a box. Available in both French and English editions @ \$56.00. A special limited edition of 350 copies, bound in leather with gilt-edged pages, with white buckram slip case, individually numbered and registered is available from Macmillan of Canada @ \$160.00

Cramond, Michael.

Game fishing in the west [by] Mike Cramond. Illus. of fish species by Lissa Calvert. [Vancouver, B.C., Mitchell Press, c1964]. 162 p. 24 cm.

1. Fishing - British Columbia.

Curry-Lindahl, Kai.

National parks of the world, by Kai Curry-Lindahl and Jean-Paul Harroy. Under the general editorship of Vera R. Webster. New York, Golden Press, 1972.

2 v. col. illus. 20 cm. (A Golden Field Guide) \$3.95 per vol. "An official publication of the International Union for Conservation of Nature and Natural Resources." Bibliography: v. 1, p. 197. Contents: v. 1 Europe, North America, South America. - v. 2: Africa, Asia, Australasia, and Oceania.

Dubach, Harold W.

An evaluation of the "Morskoi atlas," with translations from volumes I and II [by] H. W. Dubach and M. A. Slessers. Washington, U.S. Navy Hydrographic Office, 1958. xi, 441 p. 27 cm. (U.S. Hydrographic Office, Technical report, TR-38) See full bibliographic entry for the "Morskoi atlas" in this issue under Atlases Cataloged at UCLAbY Anna Blustein.

Guide to U.S. Government Maps is the title of a new book to be published by Documents Index, P.O. Box 195, McLean, VA 22101. Mr. John L. Andriot of Documents Index has advised us that editorial work on this new guide will be completed at the end of 1974. The regular price will be \$60.00, but to readers of the Information Bulletin and others who have already placed their orders the pre-publication price is \$45.00. [Special price extended to end of year.] The Guide is 1 vol. issued in looseleaf format, up-dated quarterly.

Harris, Thomas.

Down the wild rivers; a guide to the streams of California. San Francisco, Chronicle Books, [c1972,1973]. 219 p. illus. 23 cm. \$4.95 Rev. 2d ed.

Howse, Derek.

The sea chart: an historical survey based on the collections in the National Maritime Museum, [by] Derek Howse and Michael Sanderson; with an introduction by G.S. Ritchie. New York, McGraw-Hill Co. [1973] 144 p. illus., charts, facsims., maps (some col.) 29 cm. \$12.95 [Greenwich, Eng. National Maritime Museum] *Editor's Note*: A review of this item by Dr. Walter W. Ristow, Chief, Geography and Map Division, Library of Congress, appears in The American Cartographer, Vol. 1, No. 1, April 1974, p. 88.

One of the most useful periodical articles on map acquisition to appear within the last ten years is: "Sources and Methods to Latin American Flat Map Procurement", by Peter T. Johnson, in Bulletin No. 95, Geography and Map Division, Special Libraries Association (March 1974), pp. 40-47,60. Professor Johnson, and Lynn Mullins (Editor of the Bulletin), are congratulated for this important contribution.

Keuning, J.

Willem Jansz. Blaeu; a biography and history of his work as a cartographer and publisher, rev. & ed. by M. Donkersloot-DeVri. Amsterdam, Theatrum Orbis Terrarum, 1973. \$14.05

Lowe, Don.

100 southern California hiking trails, by Don & Roberta Lowe. Beaverton, OR; Touchstone Press, 1972. 224 p. illus. 23 cm.

MacMahon, Horace.

Stereogram book of contours, illustrating selected landforms. Northbrook, IL; Hubbard Press, c1972. 32 p. illus. 28 cm. Stereoscope in pocket.

México. Dirección General de Faros e Hidrografía.

Costas de México, América Central y Colombia. 2d ed. México, 1966-1 v. illus. (part fold.col.),map. (Its Cuaderno de Faros, F.H. no. 201) Kept up to date by revision sheets published in the monthly leaflet Avisos a los marinos.

Miller, Ruby M.

Pennsylvania maps and atlases in the Pennsylvania State University Libraries, by Ruby M. Miller. University Park, Pennsylvania State University Libraries, 1972. xii, 682 p. 28 cm. (Bibliographical series, no. 5) [Ruby Miller is the Map Librarian.]

Minnesota. University. Minneapolis. Wilson Library, Map Division.

Maps of Minnesota: an annotated list of sources. Mai Treude, editor, Mary A. Severson, compiler. Minneapolis, June 1974.

This list is intended as an aid to sources of Minnesota maps currently available to the public, free or for purchase. Maps are described, annotated by complete ordering information. This 14-page list is available *free* from: Map Division, Wilson Library, University of Minnesota, Minneapolis, MN 55455.

Muehrcke, Phillip.

Thematic cartography. Washington, Association of American Geographers, 1972. 66 p. illus. 28 cm. (AAG. Commission on College Geography. Resource paper #10)

Multilingual dictionary of technical terms in cartography.

Wiesbaden, F. Steiner, 1973. lxxxiii, 573 p. 29 cm.

At head of title: International Cartographic Association. Commission II.
Sample map-sheets: 3 fold. in pocket. English, French, German, Russian, and Spanish. Bibliography: p. 569-573.

Peucker, Thomas K.

Computer cartography [by] Thomas K. Peucker. [Washington, Association of American Geographers, 1972] 75 p. illus. 28 cm. (AAG. Commission on College Geography. Resource paper # 17)

Phillips, James Wendell, 1922-

Alaska-Yukon place names [by] James W. Phillips. Seattle, University of Washington Press [1973] xix, 149 p. illus. 23 cm. \$6.95 Biblio.: p.147-149.

Silveira de Braganza, Ronald Louis, 1933-

The Hill collection of Pacific voyages. Edited by Ronald Louis Silveira de Braganza and Charlotte Oakes; annotations by Jonathan A. Hill. San Diego, University Library, University of California, 1974. xv, 333 p. col.illus.

A collection, by Kenneth E. Hill and his family, of "virtually all of the reports of voyages on the Pacific made prior to 1850," now housed in the library of the University of California, San Diego.

Thomas, Morley K.

Guide to the climatic maps of Canada, by M. K. Thomas and S. R. Anderson. Toronto, Dept. of Transport, Meteorological Branch, 1967. v, 79 p. 28 cm. ([Canada. Meteorological Branch] CLI-1-67)

----- supplement. 1969.

Tyner, Judith Zink.

The world of maps and mapping; a creative learning aid. [New York] McGraw-Hill, [1973] 48, [1] p. illus., col. maps. 34 cm. Consulting editor: Norman J.W. Thrower.

U.S. Department of Agriculture. Agricultural Research Service. Western Region.

Physical and chemical properties of major Imperial Valley soils. By Eugene R. Perrier, Arnold J. MacKenzie, and Robert P. Zimmerman. ARS W-17. April 1974. Agricultural Research Service, Western Region, 2850 Telegraph Avenue, Berkeley, CA 94705. 32 p. 26 cm.

U.S. Defense Mapping Agency. Hydrographic Center.

Catalog of Publications. Publication 1-P. 1974. This publication supersedes the Catalog of Publications, N.O. PUB 1-P, 1971. Special Notice: The responsibility for the preparation of this catalog has been transferred to the Defense Mapping Agency, Hydrographic Center from the U.S. Naval Oceanographic Office, effective this issue.

For sale [\$1.30] by Sales Agents of the Defense Mapping Agency, Hydrographic Center; also by the Superintendent of Documents, U.S. Government Printing Office, Washington, DC 20402.

Publications listed in the Catalog include: Manuals, both general and navigational; Geophysics; Marine Biology; Marine Geology; Water; Ice; Instrumentation and Evaluation; and a list of Sales Agents (both U.S. and worldwide).

U.S. Department of State. Bureau of Intelligence and Research. Office of the Geographer.

Geographic Note: GE-114, June 21, 1974: "International Boundary Study: Status of Series."

The map attached to this issue is an Index to this long-valued series. The location of each of the 144 issues in this series, dating from April 1961. The Geographic Note also gives those numbers which are "out of stock", and which boundary studies are presently under production. *"Agencies of the United States Government may obtain additional information and copies of the studies by calling The Geographer, Room 8742, Department of State, Washington, D.C. 20520 (Telephone: 632-2022)."*

U.S. Department of the Interior. Bureau of Land Management.

Manual of instructions for the survey of the public lands of the United States. 1973. Prepared by the Bureau of Land Management. Technical Bulletin #6. Washington, DC, U.S. Government Printing Office, 1973. For sale by the Superintendent of Documents, U.S. Government Printing Office, Washington, DC 20402. \$7.30 Stock Number 2411-0037.

CONTENTS: Chapter I: The General Plan; II: Methods of Survey; III: The System of Rectangular Surveys; IV: Monumentation; V: Restoration of lost or obliterated Corners; VI: Resurveys; VII: Special surveys and instructions; VIII: Field Notes; IX: Plats; X: Mineral Surveys; Appendix I: Adjustment of the Solar Unit; Appendix II: Sample Field Notes; Index; Inserts: (in Pocket): No. 1: Specimen township plat; No. 2: Specimen plat, mineral-patent survey and mill site.

U.S. Forest Service. Eastern Region.

Retracement and Evidence of Public Land Surveys, by Donald D. Lappala, Land Surveyor ..., 1974. Washington, DC, U.S. Government Printing Office, 1973. 58 p. 26 cm.

CONTENTS: The upper Peninsula of Michigan is used as a model for retracing original land surveys. The retracement techniques in searching for and recovering remaining evidence requires a comprehensive knowledge of the survey system and the work of each of the deputy surveyors making the original survey. The text and illustrations in this report are representative of the Ottawa National Forest.

U.S. Geological Survey.

Mountains and Plains; Denver's Geologic Setting. [a 24-page brochure-pamph.] For sale by the Superintendent of Documents, U.S. Government Printing Office, Washington, DC 20402. 40¢ Stock Number 2401-00224.

U.S. Library of Congress. Map Division.

A list of geographical atlases in the Library of Congress, with bibliographical notes. Volume 8 [which is an] Index to Volume 7 (titles 10255-18435). Compiled by Clara Egli Le Gear. Washington, 1974. Supt. of Doc. No.: LC 5.2: G29/v.8. Stock number 3000-00070. \$5.35 For sale by the Superintendent of Documents, U.S. Government Printing Office, Washington, D.C. 20402.

U.S. Library of Congress. Geography and Map Division.

Population maps of the western hemisphere; a list of national and regional population maps from 1960 in the Geography and Map Division, Library of Congress. [By] John R. Hebert. Rev. Nov. 1971. [Washington] 1971. 21 p.

Gifts & Exchange

Nancy Pruett, Map Librarian at Southern Methodist University, and Associate Member of WAML, is kindly offering the following duplicate maps to any WAML Institutional Member, or Member's library, for the cost of postage:

Alabama. Geological Survey. Maps 13, 15-35, 37-45, 47-60, 63, 64, 65, 67-73, 75.

New Mexico. Bureau of Mines and Mineral Resources. Geologic map 1, 7-12, 14-15.

North Dakota. Geological Survey. Report of investigations No. 9, 11-12, 14-15, 19, 21, 23-26, 28.

Texas. Bureau of Economic Geology. Geologic quadrangle maps of Texas No.'s 15-21, 24-26, 37.

U.S. Geological Survey. Topographic maps of Texas. Blue-line advance proofs (not the finished published maps). There are about 8 boxes of these in alphabetical order by quadrangle name. Not complete coverage of state.

U.S. Geological Survey. Series ...

C-44

HA-294

I-239, 272, 296, 316, 332, 385, - 416, 426-427, 430-431

GQ-58, 98, 119, 248, 336, 345, 350

MF-76, 79, 177, 204-205, 219, 222, 226-227, 229, 232-233, 251, 279

MR-6, 12-14, 21, 24, 29, 33

OC-61

Please send request to:

Nancy Pruett
Map Librarian
Science/Engineering Library
Southern Methodist University
Dallas, Texas 75275

The Bancroft Library of the University of California, Berkeley has some copies of the folios of the Geologic Atlas of the United States [U.S.G.S. 1894-1945] for exchange for those folios needed to complete its collection, or for Sanborn insurance maps of western U.S. or Mexican cities. If you have any of the desired folios listed or any Sanborns which you are willing to exchange, please contact:

Philip Hoehn
The Bancroft Library
University of California
Berkeley, CA 94720

FOR EXCHANGE

18	52
24	54
29	55
30	56
36	58
38	72
42	92
45	94
48	121
49	125
50	219

NEEDED TO COMPLETE COLLECTION

79
181
183
194
202
206
209
212
214

Bench Marks!

PAUL STOUT, formerly of the Cartographic Technical Squadron, March Air Force Base, California, after 13 years as an Air Force cartographer, is now a student at Western Michigan University School of Librarianship, Kalamazoo, Michigan. This is the Master's Degree program for Map Librarians, described elsewhere in this issue.

HARTLEY PHINNEY, formerly of the Chevron Oil Field Research Company, La Habra, California, and 1973 President of the Geoscience Information Society, has been appointed Chief, Circulation and Reference, U.S. Geological Survey Library, Reston, Virginia.

WILLIAM GARRABRANT, formerly Asst. Science Librarian, Virginia Polytechnic Institute and State University, Blacksburg, Virginia, is the new Science Librarian, Glassboro State College, Glassboro, New Jersey.

RICHARD MALINSKI, Map Librarian, York University Library, Downsview, Toronto, replaces RON MacDONALD as Map Librarian, Simon Fraser University Library, Burnaby, British Columbia.

MARY LARSGAARD, Map Librarian, Central Washington State College, Ellensburg, Washington, and WAML President-Elect, has accepted an appointment to the Standards Committee, Geography and Map Division, SLA.

STANLEY STEVENS, Map Librarian, University of California at Santa Cruz, and WAML Treasurer & Editor, Information Bulletin, has been nominated by SLA Geography and Map Division Chairperson, Alberta Koerner, to serve as that Division's representative on the National Microfilm Association's Map Micro-filming Standards Committee.

LINDA COHEA, Map Librarian, University of Arizona, Tucson, is now MRS. COTTRELL.

JANET RUDD, formerly of Rand McNally & Co.'s Geographic Research Dept., Chicago, has been appointed Map Librarian, General Library, University of California, Berkeley.

IN MEMORIAM Bill M. Woods died of cancer May 1, 1974 at his home on Long Island, New York. Mr. Woods, a subscriber to the WAML Information Bulletin, was the recipient of the 1959 Honors Award of the Geography and Map Division, SLA. He was praised, at the time of that award, "for his successful work [as Map Librarian] at the University of Illinois during the past decade in building one of the largest and best-organized geography and map libraries among American universities...." He also served 10 years as Executive Director of the Special Libraries Association. WAML extends its sympathy to his survivors.

Roy V. Boswell, compiler and exhibitor of the Collection for the History of Cartography at California State University at Fullerton, wishes to make a correction to the June 1974 issue of the Information Bulletin. [see IB Vol. 5, #3, pp. 13-19] Map Number 16, as described on page 18, and illustrated on page 14, is by Alain Manesson Mallet 1630-1706, not Petrus Bertius, as Mr. Boswell had originally indicated.

INCOME-EXPENSE REPORT

For Period Fiscal Year July 1, 1973 thru June 30, 1974
and Volume 5 year of Information Bulletin

Date July 15, 1974

Previous Balance . . .

451	46
-----	----

adjusted

INCOME			AMOUNT		
Source and Explanation	Principal	Associate	Institu-		
Dues	Memberships: 90 Individual;	28 Individual;	21 tional	1,120	00
	Subscriptions to Information Bulletin = 85			445	00
	Sale of Back Issues of Information Bulletin			597	25
	Sale of Occasional Paper No. 1 = 96			384	28
Other Income	Net Income on Payments Short/Over			5	03
	Interest Earned on Funds on Deposit			25	76

TOTAL INCOME

3,028	78
-------	----

EXPENSE			AMOUNT	
Paid to	For			
Treasurer's Expenses: Invoices, Postage, Printing, etc.		46	02	
WAML Meeting Expenses: Riverside & Fresno		58	29	
Reprinting of Information Bulletin (Back Issues sales)		204	81	
Information Bulletin Production Expense (incl. Postage)		1,316	84	
General Administrative Expense		7	88	
State of California Sales Tax (collection on OP #1)		2	52	
Conversion of Bank Funds to U.S. Currency		1	25	

TOTAL EXPENSE

1,637	61
-------	----

Submitted by Stanley D. Stevens
Stanley D. Stevens, Treasurer
& Editor of Publications

NET BALANCE (A+B-C)

1,391	17
-------	----

Disposition of Net Balance:

Deduct Income Due 73/74	151.96
Add Pre-Payments for 74/75	85.00

Comments or Recommendations:

Saleable material on hand 7/1/74:

Back Issues Information Bulletin
 estimated minimum value \$285.00
 estimated maximum value \$700.00
 Occasional Paper No. 1 \$2108.00
 (incl. \$80.30 mailing cartons)

Cash on hand 7/1/74 1,324.21
 Accounts Payable:
 Sales Tax collected on
 Occasional Paper No. 1 3.60

\$2,393.00 to \$2,808.00

Stationery supplies on hand: Estimated value: \$ 156.00

Mailing envelopes	\$125.00	Promotional brochures	\$24.22
Postage	\$ 3.86	Letterhead	\$ 2.92